

8-2010

## The Importance of Compatibility and Pressure on Intentions to Engage in Distance Learning

Craig Van Slyke

*John Cook School of Business, Saint Louis University, cvanslyk@slu.edu*

Geoffrey Dick

*Mike Cottrell School of Business, North Georgia College and State University*

Thomas Case

*Information Systems, Georgia Southern University*

Virginia Ilie

*College of Communication and Information, Florida State University*

Follow this and additional works at: <https://aisel.aisnet.org/cais>

---

### Recommended Citation

Slyke, Craig Van; Dick, Geoffrey; Case, Thomas; and Ilie, Virginia (2010) "The Importance of Compatibility and Pressure on Intentions to Engage in Distance Learning," *Communications of the Association for Information Systems*: Vol. 27 , Article 22.

DOI: 10.17705/1CAIS.02722

Available at: <https://aisel.aisnet.org/cais/vol27/iss1/22>

This material is brought to you by the AIS Journals at AIS Electronic Library (AISeL). It has been accepted for inclusion in Communications of the Association for Information Systems by an authorized administrator of AIS Electronic Library (AISeL). For more information, please contact [elibrary@aisnet.org](mailto:elibrary@aisnet.org).

# Communications of the Association for Information Systems

CAIS 

## The Importance of Compatibility and Pressure on Intentions to Engage in Distance Learning

Craig Van Slyke

*John Cook School of Business, Saint Louis University*

*cvanslyk@slu.edu*

Geoffrey Dick

*Mike Cottrell School of Business, North Georgia College and State University*

Thomas Case

*Information Systems, Georgia Southern University*

Virginia Ilie

*College of Communication and Information, Florida State University*

---

### Abstract:

The study of factors that influence intentions to use information technology enabled innovations enjoys a long tradition in the information systems literature. Recently there have been calls for research that enhances our understanding of interrelationships among beliefs related to technology adoption. In addition, there has been recent interest in more closely examining specific beliefs, including perceived compatibility. In this study we use the context of distance learning to develop and test a model of use intentions. Our main focus is on two under-researched forces that may influence intentions, pressure and fit. Pressure pertains to the normative and institutional influences to engage in distance learning. Specifically, we examine how perceptions of subjective norm and voluntariness influence distance learning intentions. Compatibility concerns how well distance learning matches with the desires and past experiences of potential distance learners. We use Karahanna, Agarwal and Angst's [2006] multidimensional conceptualization of compatibility to represent compatibility beliefs. We examine both the direct and indirect impact of these factors on distance learning intentions in a nomological network that includes other beliefs (relative advantage and ease of use) drawn from diffusion theory. Data from a survey indicate that compatibility with preferred work style and values have an impact on intentions, as do voluntariness beliefs. This study points out the importance of using a multidimensional view of compatibility. In addition, results related to voluntariness indicate that in largely volitional environments institutional pressures to adopt may actually lower use intentions.

**Keywords:** individual, collaboration systems, individual use, adoption, empirical, education

Volume 27, Article 22, pp. 395-414, August 2010

The manuscript was received 4/15/2009 and was with the authors 7 months for 1 revision.

## I. INTRODUCTION

The study of factors that influence adoption decisions has a long, rich tradition in the information systems (IS) literature. Despite this long history, there remain opportunities to expand our knowledge of the forces that drive adoption decisions. This article seeks to expand the literature on adoption by examining two key areas, which we believe have not been adequately researched.

The first of these areas concerns how pressures to use an innovation influence adoption. In this study, we examine two aspects of such pressures. The first is perceived voluntariness, which is the degree to which the potential adopter perceived adoption to be volitional. This aspect primarily reflects beliefs regarding whether those in power mandate the innovation's use, and thus is primarily a "top-down" view of pressure. In contrast, normative pressures are broader, representing the perceived beliefs of important others regarding the use of the innovation. In the literature, this is often called *subjective norms*. These constructs are particularly interesting because the literature is unclear on the role these factors play in adoption, in terms of both conceptualization and empirical findings.

The second key area concerns how an innovation and its use fit with the prior experiences, preferences, and values of the potential adopter. Innovation diffusion theory uses perceived compatibility to represent this idea. While compatibility has been studied widely in the IS literature, the bulk of this literature takes a rather simplistic, single-dimensional view of compatibility. Recently, however, richer conceptualizations of compatibility have emerged [Karahanna et al., 2006; Compeau et al., 2007; Van Slyke et al., 2008]. The more recent literature views compatibility as consisting of multiple dimensions, which allows for a richer understanding of how related beliefs impact use intentions. These dimensions are compatibility with prior experience, existing work practices, preferred work style and values. This study is one of the first to empirically test these complex views of compatibility. Using a multidimensional view of compatibility is especially important if, as we find in this study, the dimensions vary in their impacts on use intentions and other beliefs.

In this article, we seek to better understand how voluntariness, subjective norms, and the various dimensions of compatibility influence use intentions. To accomplish this we use distance learning as the context of study.

The growing acceptance of the Internet and other information and communication technologies is leading to a corresponding growth in interest in Internet-based distance learning. Distance learning offers a number of advantages for both students and institutions. Increased reach is perhaps one of the most important benefits of distance learning. Students may be able to take courses that were previously unavailable to them, and institutions may be able to reach students who were previously unable to take its courses. Much in the same way electronic commerce reduces geographic barriers for consumers and merchants, so does distance learning reduce geographic barriers for learners and educational institutions. According to a 2007 report [Allen and Seaman, 2007], in the United States, over 3.5 million students took an online course in the fall of 2006. This represents a growth rate of 9.7 percent over the previous year, which is much higher than the overall college enrollment growth of 1.5 percent. This trend is expected to continue [Allen and Seaman, 2007].

However, if distance learning is to reach its potential, a number of issues must be addressed. One fundamental issue is understanding the factors that influence students' intentions to engage in distance learning. While many academic institutions have invested in various forms of distance learning technologies, students must be willing to engage in distance learning—if these investments are to pay off. Thus, it is important to examine the factors that impact students' intentions to take advantage of distance learning opportunities. In order to gain insight into this issue, we investigate the following research question:

*How do students' perceptions of pressures to use and the compatibility of distance learning with their prior experience, existing learning practices, preferred learning style and values influence their intentions to engage in distance learning?*

While distance learning goes beyond online courses, in this study we specifically study Internet-enabled distance learning. We recognize that other forms of distance learning exist, such as TV-based and correspondence courses. However, the use of Internet-based learning is of increasing importance. Therefore, we focus our attention on this form of distance learning.

We examine the above-stated research question using data from a survey administered to university students. Given the rise in interest among universities for engaging distance learning, we believe that understanding drivers of university student adoption merits more research. This article is organized as follows. We begin by providing background information on distance learning. This is followed by a discussion of our research framework, which is based on diffusion of innovation theory. Next, we describe our research methodology, followed by a discussion of the results of our analysis. We then interpret our results and finally, we offer some concluding remarks and implications for implementations of distance learning programs in academic institutions.

## II. DISTANCE LEARNING

Distance learning, as the name implies, refers to organized learning activities that take place when the learner and teacher are not collocated [Belanger and Jordan, 2000]. While learning at a distance may be facilitated by many media, including radio, television and postal mail, in this article we are specifically concerned with distance learning that is facilitated by the Internet and Internet-based technologies, including the Web, Web-based courseware, e-mail, and the like. Both asynchronous and synchronous technologies fall into this definition. For example, asynchronous technologies, such as e-mail and online discussion facilities, support asynchronous learning. Synchronous technologies, such as Web-based videoconferencing, may be used to support online learning that resembles traditional classes in that all students and the instructor "meet" at the same time, albeit online rather than face-to-face.

Many learners find distance learning to be beneficial. One of the major benefits of distance learning, particularly when asynchronous, is that it can be very convenient to the learner. In asynchronous distance learning environments, learners may cover material and contribute to discussions at whatever time and place they find convenient. As more nontraditional students are drawn to universities, the convenience of distance learning may become increasingly important [Medlin et al., 2004]. There is also research to suggest that technology-mediated learning may help improve learners' achievement, although the evidence is mixed [Jahng et al., 2007]. Interestingly, one of the benefits to institutions is also a benefit to learners. As noted earlier, distance learning removes many geographic-based barriers, allowing them to reach new markets, which is a driver of distance learning for some institutions [Allen and Seaman, 2007]. A similar comment may be made about learners. When choosing an institution, learners are no longer limited by factors such as physical distance to a campus.

Distance learning also has the potential to increase learning effectiveness [Alavi et al. 1995]. For example, discussion boards offer opportunities to extend discussions beyond the time constraints of the classroom [Van Slyke et al., 2002]. Because these facilities are typically asynchronous, students can contribute at any time (and from any location) they find convenient. These online discussions also allow students to add to the conversation after they have had a chance to reflect on the topic. In face-to-face situations, the opportunity for such extended discussion is lost when the proverbial bell rings, signaling the end of class.

Students may also perceive drawbacks to distance learning [Piccoli et al., 2001]. For example, students in online learning courses may feel isolated. Instructors may also find that teaching via distance learning is more time consuming than traditional face-to-face courses [Gueda and Ryan, 2008]. Another potential drawback to distance learning for some students is that less mature and motivated students may perform more poorly because distance learning shifts more responsibility to the learner. Further, distance learning typically requires that students employ new learning strategies, which may be problematic for some students [Piccoli et al., 2001].

The potential benefits of distance learning to learners are contingent on the learner being (or becoming) comfortable with a learning environment that is mediated by technology [Piccoli et al., 2001]. In an online learning environment, this means not only being comfortable with the idea of learning at a distance, but also requires being comfortable with the enabling technologies. Because of this, we believe that it is important to understand how learners perceive distance learning. It is similarly important to gain insights into how various distance learning-related perceptions impact intentions to engage in distance learning. In the next section, we describe the theoretical perspective that may be useful in investigating these issues.

## III. RESEARCH MODEL AND HYPOTHESES

There are a variety of theoretical lenses through which to investigate our research question, including the Technology Acceptance Model [Davis et al., 1989], Unified Theory of Acceptance and Use of Technology (UTAUT) [Venkatesh et al., 2003], and diffusion of innovation theory [Rogers, 1995]. A common thread across all of these models is the notion that potential users'/adopters' perceptions of the characteristics of an innovation have an influence on its adoption/use. The main differences across the theories pertain to what perceptions are deemed important and, to some extent, what the relationships are among the perceptions. Our research builds on recent work on technology adoption [Karahanna et al., 2006; Compeau et al., 2007]. Our interest here is in the role of

pressures and compatibility in the adoption of distance learning. Prior research has found mixed results with regards to the role of pressures (conceptualized as voluntariness and social influences) on technology adoption. In fact, some authors have found a positive relationship between voluntariness and use [Moore and Benbasat, 1991], while others have found a negative relationship [Compeau et al., 2007]. As regards social influences, their role is also mixed in impacting usage [Taylor and Todd, 1995; Van Slyke et al., 2007]. The role of perceived pressures in influencing adoption decisions remains unclear. As such, we chose to focus our interest on this key construct. Furthermore, recent research on technology adoption has emphasized the importance of compatibility in influencing technology adoption [Karahanna et al., 2006; Compeau et al., 2007]. Compatibility has been proposed to be a multidimensional construct [Karahanna et al., 2006], consisting of compatibility with prior experience, existing work practices, preferred work style, and values. Research into the influence of the various compatibility dimensions on adoption intention has not yet established the relative importance of each compatibility factor on adoption intention. In fact, IS researchers have been encouraged to further explore the role of compatibility dimensions as they play in other contexts [Karahanna et al., 2006]. For these reasons our research focuses on two main factors, namely perceived pressures to adopt and compatibility.

### Pressure—Voluntariness and Subjective Norm

As educational institutions continue to invest in distance learning [Allen and Seaman, 2007], it is possible that students may increasingly feel pressure to engage in distance learning. These institutions see opportunities to improve reach and increase instructional efficiencies; thus they may try to influence students in ways that will increase participation in distance learning. For example, required courses may be available only online. In addition, the number of seats available in traditional sections of certain courses may be severely reduced, in effect forcing many students to take the course via distance learning.

In our model, we represent beliefs regarding institutional pressures to use distance learning as perceived voluntariness. Perceived voluntariness concerns the potential learner's beliefs regarding whether the use of distance learning is of free will (voluntary) [Moore and Benbasat, 1991]. Voluntariness may be viewed as an objective concept. For example, if a required course is available only online, students may, in reality, have little choice in engaging in distance learning (of course, they could choose to change programs or schools). In line with the notion that beliefs are important drivers of behaviors [Fishbein and Ajzen, 1975], in this study we are more interested in the effect of perceived voluntariness than we are on an objective view.

Voluntariness of use is an interesting concept. On the surface, it may seem likely that the less the use of a system is seen as being voluntary, the higher use intentions will be. If you feel that you *must* use the system, then it is likely that you will intend to use the system. This view is reflected in most IS research that includes voluntariness. While there is relatively little empirical research on the impact of voluntariness, there are indications that voluntariness beliefs have a negative impact on use [Agarwal and Prasad, 1997; Karahanna et al., 1999; Compeau et al., 2007; Kishore and McLean, 2007] and future use intentions [Moore and Benbasat, 1991].

Most prior research seems to imply that if users are given a choice (their usage is voluntary), they will make less use of an IS [Compeau et al., 2007]. As such, previous research implies that in order to ensure use, IS should be made mandatory. However, perceived pressures to adopt may foster user behaviors such as resistance [LaPointe and Rivard, 2005]. Resistance can be seen as manifesting on a continuum ranging from active resistance [LaPointe and Rivard, 2005] to subtle resistance [Kostova and Roth, 2002]. It is not unusual for individuals to react to feelings of being "forced" to do something by resisting, either overtly or covertly. In the context of distance learning, it is important to understand that there may be degrees of voluntariness; voluntariness may not be a simple binary variable. Even when distance learning is not strictly mandatory, students may still feel institutional pressure to engage in distance learning. This pressure may result in subtle resistance to distance learning. Other researchers documented that users may subtly resist innovations by engaging in a practice called *ceremonial adoption* [Kostova and Roth, 2002], which means apparent compliance to satisfy institutional pressures to adopt but lack of users' internalization of the innovation. In the absence of internalization or formation of positive attitudes about the innovation's use [Kelman, 1958], usage may not be sustainable or committed [Klein and Sorra, 1996], with the final result of the innovation not being used to its fullest potential. Thus, the consequence of negative attitudes arising from a mandatory environment can be potentially "profound" [Brown et al., 2002], resulting in "compliant use" at best [Klein and Sorra, 1996], which is not sustainable over time. As such, the role of pressure to adopt may be detrimental to the adoption intention and students may react negatively to perceived institutional pressure to use distance learning. Other IS research suggests a positive relationship between voluntariness and use [Moore and Benbasat, 1991]. We believe that in the context of university-based distance learning, pressure from the institution is likely to lead to students being resistant to using distance learning in the future. Therefore, we hypothesize the following:

*H1a: Beliefs regarding the voluntariness of distance learning have a positive impact on students' distance learning use intentions.*

Normative beliefs are broader in scope than voluntariness. While universities can take actions to promote or exert pressure to use distance learning, there is a tendency in the literature to overemphasize the effects of institutional pressures [Lewis and Seibold, 1993]. Subjective norms pertain to less formal sources of influence, such as peers. By including both institutional pressures (voluntariness) and social pressures (subjective norms), we are able to get a more complete view of the impact of pressure on distance learning intentions.

While voluntariness is primarily related to “top-down” pressure, subjective norm is more all-encompassing. Subjective norm refers to an individual's beliefs regarding whether important referent others believe the focal behavior should be performed. In the context of distance learning, these “referent others” could include peers, advisors, parents, and others who are important to the student.

Subjective norms reflect an element of social influence, which is often cited as a determinant of behavior [Fishbein and Ajzen, 1975; Schepers and Wetzels, 2007]. From an institutional theory perspective, subjective norms relate to “normative isomorphism” [DiMaggio and Powell, 1983]. Normative pressures arise from interactions of individuals in different settings, such as educational settings or professional/personal networks. In a university environment, to the extent that students interact in various courses they are enrolled in with current and former peers or friends, they are subject to different normative influences that may lead them to act in a certain way (e.g., engage in distance learning). While institutional theory has primarily been tested at an organizational level, evidence suggests that normative pressures strongly impact adoption intention [Teo et al., 2003]. Normative pressures can take a number of forms, ranging from explicit, overt statements to more subtle cues, such as vicarious learning through the observation of others [Lewis and Seibold, 1993]. Here we are primarily interested in the effects of normative pressures, rather than the form these pressures take.

The influence of subjective norms in influencing adoption intentions has been found to be context dependent. Subjective norms seem to be significant in mandatory settings and not significant in voluntary settings [Venkatesh et al., 2003]. Furthermore, in mandatory settings, subjective norms appear to be more important in early stages of individual experience with the technology and its role decaying over time with sustained usage [Venkatesh and Davis, 2000]. Other studies support the role of subjective norms in influencing adoption intentions in a mandatory setting [Brown et al., 2002].

In general, based on diffusion and institutional theories, subjective norms are thought to have positive relationships with intentions. However, the empirical evidence regarding subjective norm is equivocal. A number of studies have failed to find support for the importance of subjective norm in impacting technology use intentions [e.g., Van Slyke et al., 2007], while others have found subjective norm to be a significant predictor of IS use intentions [Taylor and Todd, 1995; Harrison et al., 1997; Karahanna et al., 1999], but only in certain situations [e.g., Hartwick and Barki, 1994; Venkatesh and Davis, 2000]. Subjective norm has been found to influence instructors' intentions to teach online courses [Alshare et al., 2006]. Following the predominant thinking, we propose the following hypothesis.

*H1b: Beliefs regarding the subjective norm of distance learning have a positive impact on students' distance learning use intentions.*

Having discussed pressure-related factors, we now turn our attention to factors related to fit. These are discussed in the following section.

### **Compatibility Beliefs**

The importance of compatibility and fit in distance learning has been acknowledged [e.g., Van Slyke et al., 1998; Belanger and Jordan, 2000]. It is important that the characteristics of distance learning fit well with the past experiences and desires of the students. Perceived compatibility gives us a theoretically-grounded way in which to view this notion of fit. In the case of distance learning, compatibility reflects whether the student finds distance learning to be consistent with existing values, experiences and needs [Rogers, 2003].

In the studies that have included compatibility, results have been mixed. Some studies have found compatibility beliefs to be strong and significant predictors of use intentions [e.g., Carter and Belanger, 2003; Van Slyke et al., 2004]. Others, however, have failed to find such a relationship between compatibility and use intentions.

One reason for the mixed results may be that compatibility is a more complex construct than originally thought. Traditionally, compatibility has been treated as a unidimensional construct. However, Karahanna et al. [2006] make convincing conceptual and empirical arguments that compatibility may be better conceptualized as a

multidimensional construct. In their view, compatibility has four dimensions. Two of these dimensions deal with whether the focal innovation fits with the past. **Compatibility with prior experience** concerns whether the focal innovation fits with past encounters with instructional and learning methods. Similarly, **compatibility with existing work practices** relates to the extent to which distance learning fits with current and past ways of learning. The other two dimensions are more related to the potential adopter's desires, rather than what has happened in the past (or the present). **Compatibility with preferred work style** relates to whether distance learning fits with the potential adopter's desired way of learning. **Compatibility with values** concerns whether distance learning fits with the potential adopter's "dominant value system" [Karahanna et al., 2006].

Compatibility with prior experience and compatibility with existing work styles both pertain to how well an innovation fits with what one has experienced in the past, both in terms of general experiences and specifically with how the focal tasks have been performed. When an individual is faced with a new way of doing something, s/he must make sense of this in relation to the past. The past is a powerful force in cognitive processing. Whether explicitly or implicitly, we evaluate innovations in relation to what we already know; in other words, we compare the new to the old. Innovations that fit well with prior experiences and practices have a number of advantages. First, they more easily fit within existing mental schema. It is well documented that humans use existing mental schema to make sense of new situations [Schank and Abelson, 1977; Rumelhart and Ortony, 1986; Anderson, 1977]. For example, when an individual walks into a new restaurant, s/he looks for cues to ascertain whether to wait for a table, or to approach the counter to place an order. These cues are processed by comparing them to prior experience. Thus, the past is used to make sense of the new. The same can be said of innovations [Rogers, 2003; Van Slyke et al., 2008]. When an innovation fits within existing schema (past experiences), it is more likely to be understood and is also more likely to be accepted. Innovations that fit well with the past also typically have a lower learning curve than do more radical innovations. A more "past-compatible" innovation requires less effort at sense-making because of its fit and similarity with what one already has experienced. To the extent that distance learning contrasts with prior experiences and work practices, it is less likely to be adopted; in other words, there is a positive relationship between compatibility with past experience and existing work practices and adoption of distance learning [Karahanna et al., 2006; Rogers, 2003]. This thinking is reflected in the following hypotheses.

*H2a: Beliefs regarding the compatibility of distance learning with prior experience have a positive impact on students' distance learning use intentions.*

*H2b: Beliefs regarding the compatibility of distance learning with existing work practices have a positive impact on students' distance learning use intentions.*

In contrast with compatibility with prior experience and existing practices, compatibility with preferred work style and values pertain with the adopter's desires rather than the past. It is important to note that an innovation that does not fit well with the past, but does fit well with desires may still be adopted. A good example of this is the iPod. Traditionally, music lovers had little control over how their music was programmed. Radio stations played songs according to their playlist, and music publishers packaged songs on CDs. Music lovers either had to listen to the "prepackaged" structure or go through considerable effort to make mix tapes. With the advent of the iPod (and other MP3 players), listeners could now easily "package" music to fit their desires, not those of radio stations and publishers. Even though this did not fit well with the past, it did match well with desires and literally millions flocked to the innovation.

Similarly, if distance learning fits well with how students *want* to learn (compatibility with preferred work style) and how they think learning should occur (compatibility with values), then adoption is more likely [Compeau et al., 2007; Karahanna et al., 2006]. Whether or not distance learning is compatible with a learner may vary widely according to the learning preferences of the learners. Some people are more verbal learners. While audio technologies may certainly be a component of online courses, it is likely that most online courses are much more text-based than traditional face-to-face courses. Therefore, verbal learners may find distance learning to be less compatible. Similarly, learners who are unfamiliar or uncomfortable with computers and the Internet may find distance learning to be largely incompatible with their learning preferences. The point here is not to investigate the impact of learner characteristics (although this is a worthy area of research), but rather to point out that compatibility beliefs are likely to be very important to distance learning use intentions. Those learners who find distance learning to be a good fit with their learning preferences will be more likely to intend to use distance learning in the future. This thinking is reflected in the following hypothesis:

*H2c: Beliefs regarding the compatibility of distance learning with preferred work style have a positive impact on students' distance learning use intentions.*

Compatibility with values may also be an important influence on adoption decisions. Values pertain to one's enduring beliefs regarding a certain state of existence or set of behaviors are preferable to converse states or

behaviors [Rokeach, 1960]. Using innovations that fit well with personal values help satisfy an internal need for consistency between what an individual believes and does. Adopting an innovation that conflicts with one's values may bring about a feeling of cognitive dissonance. Using innovations that fit well with values reduces the level of dissonance [Karahanna et al., 2006]. This implies a direct relationship between compatibility with values and use. The limited empirical evidence available to date has not supported the relationship between compatibility with values and use. However, we believe that students who find that distance learning fits with their view of what should be are more likely to adopt this mode of learning. Therefore, we state the following:

*H2d: Beliefs regarding the compatibility of distance learning with values have a positive impact on students' distance learning use intentions.*

In addition to the direct effects discussed above, indirect effects through relative advantage and usefulness beliefs have also been proposed [e.g., Chau and Hu, 2001; Karahanna et al., 2006; Compeau, 2007]. For example, Chau and Hu [2001] found that compatibility had a significant, positive impact on perceived usefulness.

Innovations that fit well with past practices and experiences are more readily integrated into work habits. Therefore, we expect compatibility with prior experience and compatibility with existing work practices to have a positive impact on relative advantage beliefs. When individuals are faced with an adoption decision, they consider the degree to which changes in past practices are necessary. To the extent to which such changes are required, the relative benefit of adoption may be reduced. Further, any potential benefits may be less obvious to the potential adopter. Consider an innovation such as Microsoft Office's "ribbon" interface. This interface, which essentially merges menus and toolbars, may not be viewed as fitting well with experiences and practices. As a result, it is difficult for many users to recognize potential benefits of this arrangement. Thus, these adopters may believe that the change will lead to a net loss in work efficiency—in other words, lower relative advantage of adoption. There is some evidence that this relationship exists. Karahanna et al. [2006] found both compatibility with existing work practices and experience to influence perceived usefulness, although compatibility with experience had a negative relationship with relative advantage (Karahanna et al. recommended further research into this relationship).

We believe that the influence of compatibility with experience and existing practices will hold in a distance learning context. Students who find that distance learning fits well with their past are more likely to recognize its potential benefits when compared to other means of taking classes, as stated in the hypotheses below:

*H3a: Beliefs regarding the compatibility of distance learning with prior experiences will have a positive impact on students' relative advantage beliefs.*

*H3b: Beliefs regarding the compatibility of distance learning with existing work practices will have a positive impact on students' relative advantage beliefs.*

Compatibility with preferred work practices should also impact relative advantage beliefs. Any innovation that fits with favored ways of working should increase the beliefs that the use of the innovation will also enhance work efficiency and effectiveness. This assumes that the individual would like to work in an efficient and effective manner. If this is true, then it is straightforward to make the link between work style preferences and relative advantage beliefs. As Karahanna et al. [2006] point out, the utility of an innovation is partially a function of the fit between the use of the innovation and one's work style preferences. Therefore, we propose the following:

*H3c: Beliefs regarding the compatibility of distance learning with preferred work style will have a positive impact on students' relative advantage beliefs.*

Compatibility with values should also influence perceived relative advantage. It seems reasonable to expect that potential adopters would see little net advantage in using an innovation that conflicts with deeply held beliefs [Compeau et al., 2007]. Believing that there is an advantage to be had from adopting an innovation that conflicts with one's values is a cognitively uncomfortable proposition. There is empirical evidence to support this thinking [Compeau et al., 2007]. As a result, we expect compatibility with values to have a positive effect on use intentions, as stated in the following hypothesis.

*H3d: Beliefs regarding the compatibility of distance learning with values will have a positive impact on students' relative advantage beliefs.*

It is also possible that compatibility beliefs will influence intentions through perceived ease of use, which is defined as a user's belief regarding the degree to which using a system would be free from effort [Davis et al., 1989]. Empirical evidence supports this relationship [Chau and Hu, 2002]. To the extent to which there is a good fit between a technology and users' preferences and experiences, the technology should also be viewed as being easier to use. One reason for this is the lower learning curve that exists when a new technology fits well with prior



experience. When the use of a new technology is highly compatible with past experiences, it is easier for potential users to transfer extant knowledge to the use of the new technology, which lowers cognitive load [Karahanna et al., 2006]. A similar argument can be made regarding existing work practices. When a new technology fits well with existing ways of doing things, less cognitive effort is required to use the new technology [Karahanna et al., 2006]. Therefore, we state the following hypotheses:

*H4a: Beliefs regarding the compatibility of distance learning with prior experiences will have a positive impact on students' ease of use beliefs.*

*H4b: Beliefs regarding the compatibility of distance learning with existing work practices will have a positive impact on students' ease of use beliefs.*

It may also be that compatibility with preferred work style has an influence on perceived ease of use. When the use of a technology fits well with the way one wants to work, there should be a perception of less effort being required to use the technology, as stated below.

*H4c: Beliefs regarding the compatibility of distance learning with preferred work style will have a positive impact on students' ease of use beliefs.*

In addition, there may be a relationship between compatibility with values and ease of use beliefs. This relationship is less obvious than the others between compatibility dimensions and ease of use beliefs, but we think it exists nonetheless. When one finds that the use of an innovation is highly compatible with one's values, it may be that the effort required to learn and use the innovation may be obscured. The high desirability of using an innovation that is consistent with values may mask some of the complexity in integrating the use of the innovation, which will increase ease of use beliefs. This thinking is reflected in the following hypothesis.

*H4d: Beliefs regarding the compatibility of distance learning with values will have a positive impact on students' ease of use beliefs.*

For completeness, we also state hypotheses for the direct impact of perceived relative advantage and ease of use on distance learning intentions. Relative advantage is the degree to which the use of an innovation is superior to other means of accomplishing the same task or objective [Rogers, 1995]. While there are a number of dimensions of relative advantage [Van Slyke et al., 2008], in this study focus on the utility aspect of relative advantage (which is the norm in IS research). To the extent a student believes that using distance learning will improve the efficiency and effectiveness of his or her learning, s/he will be more likely to intend to engage in distance learning in the future. This logic is formalized in the following hypothesis:

*H5: Beliefs regarding the relative advantage of distance learning have a positive impact on students' distance learning use intentions.*

Perceived ease of use reflects the potential adopter's beliefs regarding whether the use of the innovation will be relatively free from effort. Ease of use has been widely studied in the IS literature, although support for its influence has been equivocal, with some studies finding support [e.g., Venkatesh and Morris, 2000; Plouffe et al., 2001; Van Slyke et al., 2004], and some failing to find such support [e.g., Karahanna et al., 1999; Agarwal and Prasad, 2000; Chau and Hu, 2002]. In the case of distance learning, however, we believe that ease of use beliefs will have an impact on use intentions. If students find distance learning to be effortful, they are likely to become resistant to its use. Further, according to the least effort principle [Hardy, 1989], individuals seek a "path of least resistance" when choosing information sources. Students are likely to follow a similar logic, and seek the learning modality that is least effortful. This leads to the hypothesis stated below:

*H6: Beliefs regarding the ease of use of distance learning have a positive impact on students' distance learning use intentions.*

Figure 1 summarizes our hypotheses graphically.

It is worth noting that we have omitted attitude, which is found in some intention models. Attitude is often positioned as a mediator between beliefs and intentions. When the focus of research is on the impact of beliefs on intentions, as is the case here, attitude is often omitted [Venkatesh et al., 2003]. We followed this practice and did not include attitudes as part of our model. In this section, we presented our research model and discussed its components. In the next section, we describe an empirical study used to test these hypotheses.

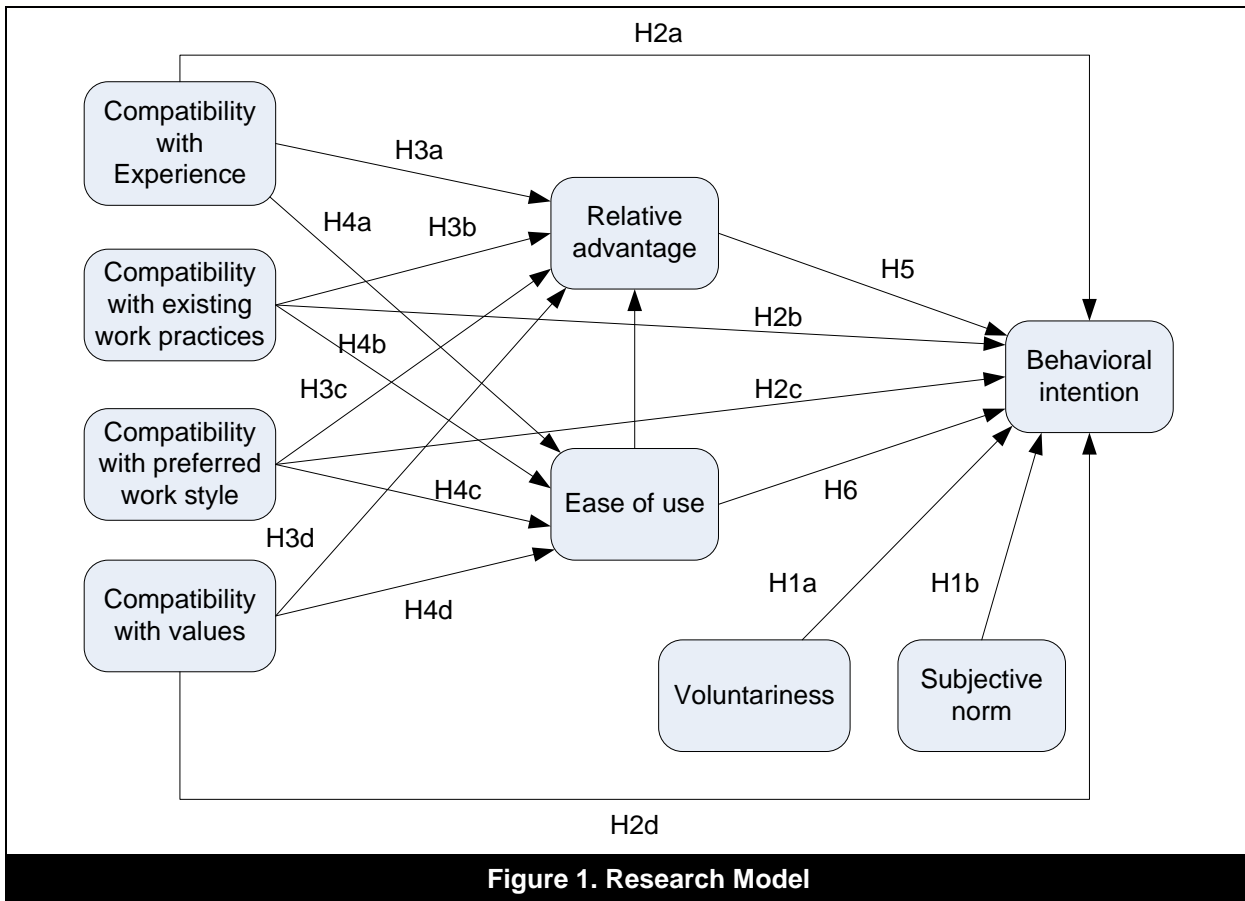

**Figure 1. Research Model**

## IV. METHOD

### Overview

In order to test the efficacy of the hypotheses stated in the previous section, we conducted an empirical study. We surveyed students enrolled in a large state-supported university in the Southeast United States. Data were collected in a required course for business majors. This course was primarily offered in an online format, although a small percentage of students could take the course in a traditional, face-to-face format. Scale items were derived from previously validated measurement scales. Factor analysis and descriptive statistics were computed using SPSS 13.0, and SmartPLS was used to test the hypotheses. Participants were provided with a brief definition of distance learning as “the use of information technology to enhance or replace traditional instructional delivery methods.”

### Subjects

Subjects were recruited from students enrolled in a large public university. A convenience sample was used, and students were offered extra credit for completing the survey. A total of 334 usable responses were collected. Table 1 provides descriptive information about the participants.

Table 1: Participant Descriptive Statistics		
Characteristic	Mean	Std. Dev.
Work experience (years)	3.85	5.646
Computer experience (years)	10.45	4.122
Age (years)	24.02	6.029
Hours per week using Web	19.35	23.356

As one might expect from a student-based sample, the participants were relatively young, with a mean age of twenty-four years. However, it should be noted that there was representation from older learners; the maximum age was fifty-four years. Participants were relatively heavy Web users, reporting a mean of nineteen hours online per week. Despite their young age, participants reported having considerable experience with computers (mean = 10.45 years). Just over one-half (54 percent) of the participants were male. Virtually all (99 percent) participants reported

having access to a computer with an Internet connection. Most of the participants reported having experience, with approximately 90 percent reporting taking at least one course with a distance learning component.

### Measurement Instrument

Measurement scales were derived from previously-published scales. With the exception of the compatibility scales, scales for the innovation characteristics were drawn from Moore and Benbasat [1991], while other sources were used for subjective norms and use intentions. Compatibility scales were derived from Karahanna et al. [2006]. All items were measured on a seven-point, Likert-type scale using the anchors “strongly disagree” (1) and “strongly agree” (7). Descriptive statistics for each scale are provided in Table 2. Scale items are provided in an appendix.

Scale	Mean	Std. Dev.
Relative advantage	4.4615	1.2517
Compatibility with experience	4.5974	1.6498
Compatibility with existing work practices	4.2549	1.5753
Compatibility with preferred work style	4.1679	1.5753
Compatibility with values	5.0353	1.6178
Ease of use	4.7251	1.3414
Voluntariness	4.6274	1.5734
Subjective norm	3.2139	1.3378
Use intentions	5.1453	1.6168

Factor analysis was also performed to assess convergent and discriminant validity. We used a confirmatory factor analysis approach with nine factors (corresponding to the nine scales) with maximum likelihood for the initial extraction and promax oblique rotation. The initial factor analysis revealed issues with a number of items. Problematic items were examined and eliminated where appropriate. The final version of the factor analysis is shown in Appendix B. Only one problem item was found in the final analysis. One relative advantage item (“Distance learning enhances my effectiveness when learning”) loaded more highly on the compatibility with preferred work style than on relative advantage. Because this item also loaded highly on the expected factor, and in order to more fully represent the concept of relative advantage (no other item included the notion of effectiveness), we decided to retain this item.

As a final check of scale validities, we followed the recommendations of Gefen et al. [2000] and compared inter-scale correlations to average variance explained (AVE) values for each scale. These values, along with composite reliability, are shown in Table 3. As can be seen in the table, in all cases the AVE is larger than the largest inter-scale correlation, thus indicating an acceptable level of discriminant validity. These results confirm those found in the

	CR	BI	CTEWP	CTExp	CTPWS	CTVal	EOU	RA	SN	Vol
BI	0.979	<b>0.969</b>								
CTEWP	0.824	0.508	<b>0.781</b>							
CTExp	0.862	-0.303	-0.774	<b>0.828</b>						
CTPWS	0.982	0.614	0.702	-0.376	<b>0.965</b>					
CTVal	0.955	0.586	0.441	-0.437	0.376	<b>0.901</b>				
EOU	0.921	0.601	0.396	-0.216	0.456	0.473	<b>0.892</b>			
RA	0.957	0.565	0.571	-0.289	0.777	0.340	0.436	<b>0.939</b>		
SN	0.802	0.292	0.318	-0.101	0.417	0.043	0.184	0.380	<b>0.767</b>	
Vol	0.933	0.241	-0.013	0.055	0.065	0.106	0.228	0.068	0.043	<b>0.907</b>

**Legend**

CTEWP: Compatibility with existing work practices  
 CTExp: Compatibility with experiences  
 CTPWS: Compatibility with preferred work style  
 CTVAL: Compatibility with values  
 RA: Relative advantage

SN: Subjective norms  
 Vol: Voluntariness  
 EOU: Ease of use  
 BI: Behavioral intention  
 CR: Composite reliability

confirmatory factor analysis reported earlier. However, there are some inter-scale correlations that are sufficiently large to cause concern. Compatibility with existing work practices is highly correlated with compatibility with prior experience, and compatibility with preferred work style is highly correlated with relative advantage. Despite the high correlations, we decided to treat these as separate scales because, (1) the AVE for each scale was higher than the correlation, which meets recommended heuristics, (2) the scales are conceptually different, and (3) the confirmatory factor analysis confirmed the nine-factor solution. However, we recommend caution when interpreting results related to these constructs.

## V. RESULTS

Partial least squares (PLS), using SmartPLS software, was used to analyze the data and test our hypotheses. As a preliminary step, we used regression to test a number of demographic and experiential variables for their ability to predict use intentions. These included age, computer experience, work experience and gender. Results indicate that only years of computer experience is a significant predictor of use intentions ( $p < 0.05$ ). Further testing indicated that computer experience was not a significant predictor of use when our study variables were also included in the analysis. Because of this, we did not include computer experience as a covariate in the hypothesis testing.

To test the hypotheses stated earlier, we used the PLS technique to analyze a path model corresponding to the research model presented earlier. The  $R^2$  values were 0.608 for use intention, 0.613 for relative advantage, and 0.331 for ease of use. Figure 2 shows the research model with beta coefficients on the paths.

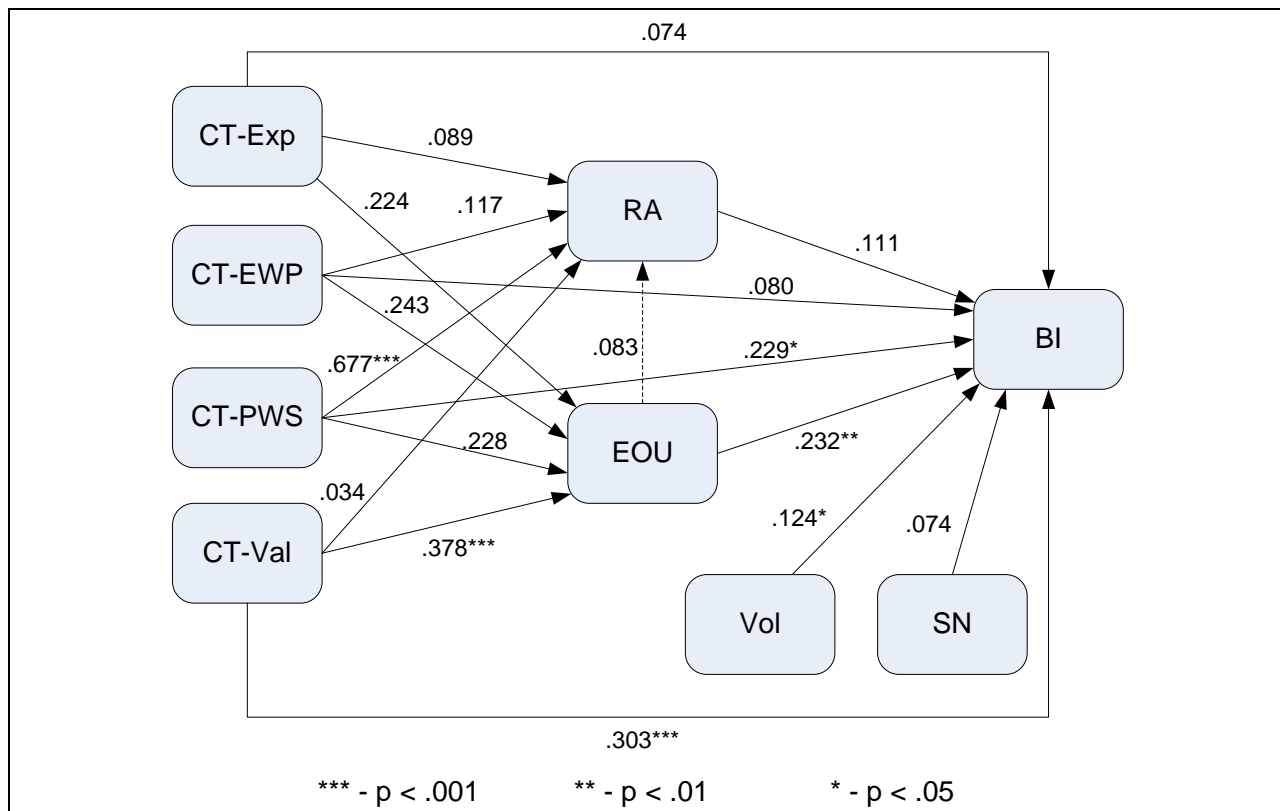

**Figure 2. Research Model with Results**

As the figure indicates, there was mixed support for our hypotheses. Voluntariness (H1a), compatibility with preferred work style (H2c) and values (H2d), and ease of use were significant predictors of intentions, while the other hypothesized factors were not. Compatibility with preferred work style is the only significant predictor of relative advantage. The two compatibility beliefs seem to be the strongest predictors of intentions. These results are discussed in the next section.

## VI. DISCUSSION

One conclusion we can draw from our results is that the research model is quite effective in explaining distance education use intentions. The  $R^2$  value of 0.608 for use intentions compares favorably to other studies of information technology behavioral intentions. From this, we conclude that our research model provides a reasonable framework for investigating distance learning intentions.

Turning to individual factors, we see that students' use intentions of distance learning are driven by a variety of factors. Significant effects come from two dimensions of compatibility (values and preferred work style), ease of use, and voluntariness. Interestingly, there are no significant impacts from relative advantage, compatibility with experience, existing work practices or subjective norm. We discuss these findings and their implications below.

Interestingly, it seems that both pressure to use and the fit of distance learning have an impact on use intentions. However, in both cases, only certain aspects influence intentions. Regarding pressure, voluntariness impacts use intentions, but subjective norms do not. Regarding fit, compatibility with preferred work style and values are significant, but compatibility with experiences and existing work practices are not.

Our results with respect to voluntariness are quite interesting, especially when contrasted with those for subjective norm. First, it is interesting that voluntariness is significant, while subjective norm is not. Both of these factors relate to pressures to use distance learning. Subjective norm is broader in scope, focusing on the influence of peers and significant others. In contrast, voluntariness is more about the lack of "top-down" pressures—not being "forced" to use distance learning. This study finds that peer pressure has little influence on distance learning intentions. The perceived degree of institutional pressure, however, is important in influencing students' intentions to engage in distance learning. While voluntariness is clearly significant in our regression equation, its sign is the opposite of what has been found in prior research. Students may resist being forced to take courses online. This is interesting, given the high mean response for use intentions (5.15 out of 7). Students seem to be generally favorable toward distance learning, but appreciate when it is their choice, not when they feel forced to engage in distance learning. When students feel that the decision is theirs to make, rather than an edict, they may have a more positive view of distance learning, which leads to higher use intentions. Administrators may wish to consider this finding when deciding on what courses to offer online. Pressure to engage in online learning may be counterproductive in contexts where resistance is possible and when use cannot be fully mandated. Offering elective courses online may be an effective way to promote distance learning. If required courses are offered only online, students may feel that they are being forced to engage in distance learning, and as a result may develop resistance. Similarly, offering both online and face-to-face sections of required courses may increase perceptions of voluntariness, which may lead to greater acceptance of distance learning.

Our finding of a positive relationship between voluntariness and use intentions is contrary to findings in other studies. This may be, in part, due to differences in context. Prior studies used a variety of innovations and contexts, including the use of the Web [Agarwal and Prasad, 1997], Windows as a replacement for MS-DOS [Karahanna et al., 1999], personal work stations [Moore and Benbasat, 1999], hospital information systems [Compeau et al., 2007], and a software development CASE tool [Kishore and McLean, 2007]. For most of these contexts, there may exist a feeling that the use of the focal technology is largely mandatory; in other words, few viable alternatives exist. This is borne out by the voluntariness means for the studies, which, with one exception, are substantially lower than ours. Only Agarwal and Prasad [1997] had a voluntariness mean higher than ours, which was 4.63 on a scale of 7. In our context, students typically have many alternatives to taking a course online. There may be face-to-face sections offered, or students may have the option of taking the course at another institution and transferring credits to their home university. Students are used to having choices in times, days, and professors when taking courses. When these choices are taken away, it is possible that students react negatively, which would lead to a positive relationship between voluntariness and use intentions.

Results related to compatibility are interesting, in that they clearly illustrate the utility of a multidimensional view of compatibility. In the past, the bulk of the research into this construct has considered it to be unidimensional. The findings that only some compatibility dimensions have a significant impact on intentions clearly support Karahanna et al.'s [2006] multidimensional view of compatibility. A unidimensional view of compatibility may have obscured the impact of fit. By using a multidimensional perspective, we were able to demonstrate the importance of fit with preferences and values. This finer-grained view enables us to provide more detailed insights for both researchers and practitioners. We also believe that it may be useful to develop more complete views of other important constructs, such as relative advantage (which we discuss below).

Delving more deeply into the compatibility results reveals that students' intentions seem to be driven by what they want, rather than what they have experienced in the past. Neither of the two past-focused compatibility dimensions (experience and existing work practices) is significant. In contrast, the significant dimensions seem to be more oriented toward what students feel should be, rather than what has been. More specifically, we found compatibility with values to play a major role in influencing students' use intentions and their perceptions of ease of use. These results confirm Karahanna's et al.'s claim that "compatibility with values might well assume primacy in the minds of potential adopters" [2006, p. 800]. While these authors did not find a direct link between compatibility with values and usage, they found this dimension of compatibility to strongly influence other beliefs. We responded to Karahanna et al.'s call for more research into the value dimension of compatibility and found a direct link between

compatibility with values and students' use intentions. Therefore, in an academic context with distance learning technologies, students' usage intentions seem to be largely driven by whether the technology fits with their value system. These results extend Karahanna et al.'s findings regarding the important role of the value component of compatibility in an academic setting.

Results related to compatibility with prior experiences indicate this dimension of compatibility has an impact on students' perceptions of ease of use. Our results confirm previous findings [Karahanna et al., 2006; Compeau et al., 2007]. There were no impacts of this dimension on relative advantage or use intentions in our context. While some studies [Karahanna et al., 2006] found a direct effect from compatibility with experience and use, we did not observe this link in an academic context. This may be because many students did not have a lot of prior experience with distance learning, and so their use intentions were not affected by compatibility with prior experiences.

Our results indicate that all dimensions of compatibility impact students' perceptions of ease of use. To the extent the technology fits with students' values, experiences, work style, and work practices, the technology is seen as easy to use. These results suggest ease of use perceptions can be influenced by altering students' perceptions of compatibility. Our results confirm prior research [Karahanna et al., 2006; Compeau et al., 2007].

Compatibility with preferred work style relates to how students want to learn, rather than how they have learned in the past. When students find that distance learning fits with the way they like to learn, they are likely to use this mode of learning. A similar statement can be made about compatibility with values. Today's students are highly value-driven overall, and the importance of values seems to carry over to distance learning. Examining the beta coefficients in our results provides evidence of the importance of values. The beta for compatibility with values is the largest coefficient in our regression equation, indicating that it has the largest impact on use intentions.<sup>1</sup> It is also interesting to note that prior studies using Karahanna et al.'s [2006] compatibility scales did not include compatibility with preferred work style in their empirical analysis due to measurement problems [Karahanna et al., 2006; Compeau et al., 2007]. We did not have the same measurement issues, so we were able to include this scale in our analysis.

Taken together, it seems that students want the use of distance learning to be of their own choosing and that the choice will be highly dependent on whether distance learning fits with the way learning should be. Students are not motivated by what others want them to do (whether peers or the institution), nor are they driven by what has been done in the past. It seems that they are willing to use distance learning, but only if it fits well with the way they want to learn and with their value system.

The degree of effort required to engage in distance learning is also important to the adoption decision, as evidenced by the significance of ease of use. While the students in our sample find distance learning relatively easy to use (based on the mean value of ease of use), our results indicate that the importance of ease of use should not be discounted. Given the increasingly ubiquitous nature of information technology, researchers may be tempted to omit ease of use from future studies. Based on our results, we would advise against this thinking. It should be noted that the wording of our ease of use questions does not clearly include the nontechnology aspects of distance learning. It is possible that ease of technology usage and ease of learning online have different effects on intentions. This may be a fruitful avenue for future research.

The only significant determinant of relative advantage is compatibility with preferred work style. Contrary to our expectations, the other dimensions of compatibility did not have significant relationships with relative advantage. A potential explanation for this finding may come from the fact that we focused on utilitarian aspects of relative advantage (usefulness), as is the norm with information systems research. It may be that the other compatibility dimensions impact non-utilitarian aspects of relative advantage. For example, compatibility with values may have a strong impact on perceived enjoyment; a user may not enjoy using an innovation that is at odds with his/her values. Thus, future research should expand our view of relative advantage beyond the usefulness dimension, as we discuss below.

Interestingly, perceptions of the relative advantage of distance learning do not seem to be important drivers of use intentions. This finding is in conflict with earlier studies, which tend to support the importance of relative advantage [e.g., Van Slyke et al., 2004]. One possible reason for this finding is that in IS research, we tend to focus on the usefulness aspect of relative advantage. In fact, researchers have stated that relative advantage is synonymous with perceived usefulness [Van Slyke et al., 2008]. Our study and measures followed this dominant thinking by focusing

<sup>1</sup> It should be noted that while the beta for compatibility with values is larger than that for compatibility with preferred work style, it is unlikely that these coefficients are significantly different.

on distance learning's impact on efficiency, performance, and the like. However, there may be other important sources of distance learning relative advantage, such as convenience. In addition, students may consider goals beyond learning when evaluating the relative advantage of distance learning. For example, they may be concerned about issues such as work load and grades (which may not correlate perfectly with learning). Distance learning options may be advantageous in terms of flexibility in scheduling, which may also impact whether a student can stay on track for timely graduation. Thus, it may be fruitful for future research to use qualitative methods to uncover other dimensions of relative advantage in a distance learning context. Quantitative studies may also examine the effects of a broader array of relative advantage dimensions in various contexts including distance learning.

### Implications for Practice

Those who wish to promote distance learning may be able to use our research to help guide their efforts. Two clear messages come through. First, it is likely that attempts to force students to engage in distance learning have the potential to backfire. Given our results related to voluntariness, we suggest that institutions promote, rather than mandate, distance learning. Mandates may work in the short-term, but may bring about resistance in the long run. Students want to come to their own decisions about whether to use distance learning, so it may be more effective to focus on demonstrating the fit of distance learning with students' preferences and values.

Given the importance of fit with preferences, those interested in promoting distance learning should first take the time to understand the preferences of today's learners. Examining research into millennial students may be helpful. Today's youth are growing up in an "on-demand" world of instant communication and broad social networks. When used properly, distance learning technologies enable learning to fit with these realities. For example, streaming video can be used to allow students to view lectures and demonstrations at their convenience, rather than at prescribed times and places. Many distance learning applications have the capability to have chat rooms, online forums, and the like. These technologies fit well with students' preferences for rapid-fire, text-based communication. Institutions and software companies interested in distance learning may be well advised to study the success of technologies such as the iPod, text messaging, and social networking sites (e.g., Facebook). Understanding what young users like about these technologies may provide cues for the future development of distance learning.

Of course, "fit" is likely to be very context dependent. Targeting nontraditional students may require different characteristics than targeting younger learners. For example, when targeting traditionally-aged students, replacing text-based readings with short, YouTube style videos may be effective. However, older learners may be more comfortable with materials that more closely resemble traditional textbooks. Thus, we believe that it is important for institutions to understand their students' preferences when promoting distance learning. Further, it is important that promotional efforts emphasize how distance learning fits with learners' preferences and values, rather than focusing on efficiency factors.

### Limitations

As is the case with any research, the study reported here has a number of limitations. First, we used a convenience sample drawn from a single institution, which limits generalizability to some extent. It would be useful for future studies to include institutions with differing levels of voluntariness. Further, our findings are likely dependent on our choice of context. It is likely that findings may be different in other contexts. Finally, we took a snapshot view of the adoption process. In future research, it would be interesting to use a more longitudinal perspective to investigate whether the impacts studied herein vary across time.

## VII. CONCLUSIONS

The spread of distance learning continues as universities and other organizations seek more efficient means of teaching. If distance learning is to meet its full potential, it is important to understand how learners perceive distance learning. In this study, we contribute to this understanding by demonstrating that a variety of beliefs contribute to distance learning use intentions. We show both direct and indirect effects of various beliefs on students' intentions to engage in distance learning. With regard to direct effects, we show that in a distance learning context, the factors influencing students' use intentions are perceived ease of use, voluntariness, and compatibility with preferred work style. In addition, compatibility with preferred work style and compatibility with values impact students' perceptions of the ease of use and relative advantage of distance learning over traditional instructional methods.

One important contribution of this research pertains to the differential impacts of the compatibility construct on use intentions and other important beliefs (such as EOU and relative advantage). We find that in a distance learning context, the only two dimensions of compatibility that directly and indirectly influence students' intentions are the ones related to students' future desires (and not with past experiences). These results suggest that compatibility beliefs vary by context. Thus, despite the fact that compatibility is viewed as a multidimensional construct, only some of its dimensions may significantly impact beliefs and intentions based on the context of study. Various researchers

pointed out the importance of context in IS research [Chiasson and Davidson, 2005]. As we show here, in a distance learning context, compatibility with preferred work style and with values are the only dimensions of compatibility that have both direct and indirect effects on use intentions. In other words, students focus on what “should be” and not what “it has been.”

In addition, this research sheds more light into the important role of compatibility with values as one important dimension of compatibility in a distance learning context. We respond to calls for more research into the role of this particular dimension of compatibility [Karahanna et al., 2006] and find that the fit with one’s value system is a significant driver of intentions. While Karahanna et al. [2006] did not find direct effects of this dimension on use of a CRM application, they speculated that “compatibility with values may assume primacy in the minds of potential adopters” [p. 800]. Our results actually show that value fit is one of the most significant predictors of students’ intentions to engage with distance learning.

Further, we show the important role of compatibility with preferred work style, which has both direct and indirect effects on use intentions. While Karahanna et al. [2006] had to drop this construct from their model due to high correlations with usefulness, one question still remains: “whether this dimension [compatibility with preferred work style] in its current form should be retained as part of the compatibility construct?” [Karahanna et al., 2006, p. 798]. Based on this study’s results, our answer is “yes,” this dimension of compatibility is important, at least in a distance learning context.

One other contribution of this study pertains to the finding about the impacts of voluntariness beliefs on use intentions. We show that making distance learning voluntary (as opposed to mandatory) could lead students to engage more with this type of learning. Universities and administrators should thus promote distance learning by giving students a choice between this type of learning and the traditional face to face environment (rather than mandate distance learning).

We also contribute to the adoption literature by showing that in a distance learning context, peer pressures do not influence students’ use intentions. These results corroborate Venkatesh et al. [2003] with respect to the differential impact of this construct on use intentions based on context of study. These results seem to suggest that students make individualized decisions and they are not motivated by the beliefs of others while engaging in distance learning. However, it should be noted that we did not include the influence of vicarious trials (exposure to others’ use of distance learning) [Rogers, 2003]; it may be that students are influenced by their peers’ use of distance learning. Future research should further test this finding in other distance learning contexts.

Institutions that wish to promote distance learning may be able to use our results to develop programs that improve learners’ perceptions of learning at a distance, which will ultimately lead to larger numbers of students engaging in distance learning.

Our research clearly shows the importance of fit between students’ preferences and values and distance learning. Students who find a disconnect between what they want and what is offered by distance learning are likely to reject this innovation, to the possible detriment of both learners and institutions. Thus it is incumbent on those who promote distance learning to take pains to understand what students want. Failing to do so may lead to distance learning failing to live up to its considerable promise.

## REFERENCES

- Agarwal, R. and J. Prasad (1997) “The Role of Innovation Characteristics and Perceived Voluntariness in the Acceptance of Information Technologies”, *Decision Sciences* 28(3), pp. 557–582.
- Agarwal, R. and J. Prasad (2000) “A Field Study of the Adoption of Software Process Innovations by Information Systems Professionals”, *IEEE Transactions on Engineering Management* (47)3, pp. 295–308.
- Alavi, M., B. Wheeler, J. Valacich (1995) “Using IT to Reengineer Business Education: An Exploratory Investigation of Collaborative Telelearning”, *MIS Quarterly* (19)3, pp. 293–312.
- Allen, E. and J. Seaman (2007) *One Nation: Five Years of Growth in Online Learning*, Boston: Sloan Consortium.
- Alshare, K., O. Kwun, E. Grandon (2006) “Determinants of Instructors’ Intentions to Teach Online Courses: A Cross-Cultural Perspective”, *Journal of Computer Information Systems* (46)3, pp. 87–95.
- Anderson, Richard C. (1977) “The Notion of Schemata and the Educational Enterprise: General Discussion of the Conference” in Anderson, R.C., R. Spiro, W. Montague (eds.) *Schooling and the Acquisition of Knowledge*, Hillsdale, NJ: Erlbaum.



- Bélanger, F. and D. Jordan (2000) *Evaluation and Implementation for Distance Learning: Technologies, Tools and Techniques*, Hershey, PA: Idea Group Publishing.
- Brown, S., et al. (2002) "Do I Really Have To? User Acceptance of Mandated Technology", *European Journal of Information Systems* (11), pp. 283–295.
- Carter, L. and F. Belanger (2005) "The Utilization of e-Government Services: Citizen Trust, Innovation and Acceptance Factors", *Information Systems Journal* (15)1, pp. 5–25.
- Chau, P.Y.K. and P.J. Hu (2001) "Information Technology Acceptance by Individual Professionals: A Model Comparison Approach", *Decision Sciences* (32)4, pp. 699–719.
- Chau, P.Y.K. and P.J. Hu (2002) "Examining a Model If information Technology Acceptance by Individual Professionals: An Exploratory Study", *Journal of Management Information Systems* (18)4, pp. 191–229.
- Compeau, D., D. Meister, C. Higgins (2007) "From Prediction to Explanation: Reconceptualizing and Extending the Perceived Characteristics of Innovating", *Journal of the Association for Information Systems* (8)1, pp. 409–439.
- Davis, F.D., R. Bagozzi, P. Warshaw (1989) "User Acceptance of Computer Technology: A Comparison of Two Theoretical Models", *Management Science* (35)8, pp. 982–1003.
- DiMaggio, P. and W. Powell (1983) "The Iron Cage Revisited: Institutional Isomorphism and Collective Rationality in Organizational Fields", *American Sociological Review* (48)2, pp. 147–160.
- Fishbein, M. and I. Ajzen (1975) *Belief, Attitude, Intention and Behavior: An Introduction to Theory and Research*, Reading, MA: Addison-Wesley.
- Gudea, S. and T. Ryan (2008) *Expectations and Demands in Online Teaching: Practical Experiences*, Hershey, PA: IGI Global.
- Hardy, A.P. (1982) "The Selection of Channels When Seeking Information: Cost/Benefit vs. Least Effort", *Information Processing & Management* (18), pp. 289–293.
- Harrison, D.A., P. Mykytyn, C. Riemenschneider (1997) "Executive Decisions About Adoption of Information Technology in Small Business: Theory and Empirical Tests", *Information Systems Research* (8)2, pp. 171–195.
- Hartwick, J. and H. Barki (1994) "Explaining the Role of User Participation in Information Systems Use", *Management Science* (40)4, pp. 440–465.
- Jahng, N., D. Krug, Z. Zhang (2007) "Student Achievement in Online Distance Education", *European Journal of Open, Distance and E-Learning* (2007)1.
- Karahanna, E., R. Agarwal, C. Angst (2006) "Reconceptualizing Compatibility Beliefs in Technology Acceptance Research", *MIS Quarterly* (30)4, pp. 781–804.
- Karahanna, E., D. Straub, N. Chervany (1999) "Information Technology Adoption Across Time: A Cross-Sectional Comparison of Pre-Adoption and Post-Adoption Beliefs", *MIS Quarterly* (23)2, pp. 183–213.
- Kelman, H. (1958) "Compliance, Identification, and Internalization: Three Processes of Attitude Change", *Journal of Conflict Resolution* (2)1, pp. 51–60.
- Kishore, K. and E. McLean (2007) "Reconceptualizing Innovation Compatibility as Organizational Alignment in Secondary IT Adoption Contexts: An Investigation of Software Reuse Infusion", *IEEE Transactions on Engineering Management* (54)4, pp. 756–775.
- Klein, K. and J. Sorra (1996) "The Challenge of Innovation Implementation", *Academy of Management Review* (21), pp. 1055–1080.
- Kostova, T. and K. Roth (2002) "Adoption of an Organizational Practice by Subsidiaries of Multinational Corporations: Institutional and Relational Effects", *Academy of Management Journal* (45)1, pp. 215–233.
- Lapointe, L. and S. Rivard (2005) "A Multilevel Model of Resistance to Information Technology Implementation", *MIS Quarterly* (29)3, pp. 461–491.
- Leung, E. and Q. Li (2006) "A Model for Personalized Course Material Generation Based on Student Learning Abilities and Interests" in *Proceedings of the 5th International Conference on Web-Based Learning* (July), Penang, Malaysia, pp. 25–37.
- Lewis, L. and D. Seibold (1993) "Innovation Modification During Intraorganizational Adoption", *Academy of Management Review* (18)2, pp. 322–354.
- Medlin, D., S. Vanny, D. Dave (2004) "An Internet-Based Approach to the Teaching of Information Technology: A Study of Student Attitudes in the United States", *International Journal of Management* (21)4, pp. 427–434.

- Moore, G.C. and I. Benbasat (1991) "Development of an Instrument to Measure the Perceptions of Adopting an Information Technology Innovation", *Information Systems Research* (2)3, pp. 192–222.
- Plouffe, C., J. Hulland, M. Vandenbosch (2001) "Research Report: Richness versus Parsimony in Modeling Technology Adoption Decisions: Understanding Merchant Adoption of a Smart Card-Based Payment System", *Information Systems Research* (12)2, pp. 208–222.
- Rokeach, M. (1960) *The Open and Closed Mind: Investigations into the Nature of Belief Systems and Personality Systems*, New York: Basic Books.
- Rogers, E.M. (2003) *Diffusion of Innovations*, New York: The Free Press.
- Rumelhart, D.E. and A. Ortony (1977) "The Representation of Knowledge in Memory" in Anderson, R.C., R.J. Spiro, W.E. Montague (eds.) *Schooling and the Acquisition of Knowledge*, Hillsdale, NJ: Lawrence Erlbaum and Associates, pp. 99–136.
- Schank, R.C. and R.P. Abelson (1977) *Scripts, Plans, Goals, and Understanding*, Hillsdale, NJ: Lawrence Erlbaum and Associates.
- Schepers, J.J.L., M. Wetzels (2007) "A Meta-Analysis of the Technology Acceptance Model: Investigating Subjective Norm and Moderation Effects", *Information and Management* (44)1, pp. 90–103.
- Taylor, S. and P. Todd (1995) "Understanding Information Technology Usage: A Test of Competing Models", *Information Systems Research* (6)2, pp. 144–176.
- Teo, H.H., K.K. Wei, I. Benbasat (2003) "Predicting Intention to Adopt Interorganizational Linkages: An Institutional Perspective", *MIS Quarterly* (27)1, pp. 19–49.
- Van Slyke, C., F. Bélanger, C. Comunale (2004) "Adopting Business-to-Consumer Electronic Commerce: The Effects of Trust and Perceived Innovation Characteristics", *The Data Base for Advances in Information Systems* (35)2, pp. 32–49.
- Van Slyke, C., F. Belanger, M. Kittner (1998) "Distance Education: A Telecommuting Perspective" in *Proceedings of the Fourth Americas Conference on Information Systems* (August), Baltimore.
- Van Slyke, C., et al. (2008) "Implications of Researcher Assumptions about Relative Advantage and Compatibility", *The Database for Advances in Information System* (39)2, pp. 50–65.
- Van Slyke, C., H. Lou, J. Day (2002) "Impact of Perceived Innovation Characteristics on Students' Intention to Use Groupware", *Information Resource Management Journal* (15)1, pp. 5–12.
- Van Slyke, C., et al. (2007) "Perceived Critical Mass and the Adoption of a Communication Technology", *European Journal of Information Systems* (16)3, pp. 270–283.
- Venkatesh, V. and F.D. Davis (2000) "A Theoretical Extension of the Technology Acceptance Model: Four Longitudinal Field Studies", *Management Science* (46)2, pp. 186–204.
- Venkatesh, V. and M. Morris (2000) "Why Don't Men Ever Stop to Ask for Directions? Gender, Social Influence and Their Role in Technology Acceptance and Usage Behavior", *MIS Quarterly* (24)1, pp. 115–139.
- Venkatesh, V., et al. (2003) "User Acceptance of an Information Technology: Toward a Unified View", *MIS Quarterly* (27)3, pp. 425–478.

## APPENDIX A—SCALE ITEMS

### *Relative Advantage*

Distance learning enhances my effectiveness when learning.  
Distance learning improves the quality of my learning.  
Overall, taking distance learning classes improves my learning.

### *Compatibility w/ Experience*

Distance learning is a new experience for me.  
Distance learning is not similar to anything I've done before.  
Distance learning is different from other experiences I have had.

### *Compatibility w/ Existing work practices*

Distance learning is compatible with most aspects of the way I typically learn. (dropped)  
Distance learning forces me to change my existing method of learning.  
Distance learning requires a change in the way I currently learn.

### *Compatibility w/ Preferred work style*

Taking distance learning classes fits my preferred way of learning.  
Distance learning enables me to learn in the way I prefer.  
Distance learning fits well with the way I like to learn.  
Distance learning fits my preferred method for learning.

### *Compatibility w/ Values*

Distance learning runs counter to my values.  
Distance learning does not fit with the way I view the world.  
Distance learning goes against what I believe learning should be.  
Distance learning is not appropriate for a person with my values regarding learning.  
Distance learning runs counter to my values about learning.

### *Ease of Use*

I believe that it is easy to get distance learning technologies to do what I want them to do.  
Overall I believe that distance learning technologies are easy for me to use.

### *Voluntariness*

Taking distance learning classes is voluntary (as opposed to required by university).  
My university does not require me to take distance learning classes.  
Although it might be helpful, taking distance learning classes is certainly not required.

### *Subjective Norm*

My friends think I should take distance learning classes.  
I feel a strong peer pressure to take distance learning classes.  
People who influence me think that I should take distance learning classes.  
People who are important to me think that I should take distance learning classes.

### *Use Intentions*

I would take distance learning classes.  
Taking distance learning classes is something I would do.  
I could see myself taking distance learning classes.

## APPENDIX B—FINAL FACTOR ANALYSIS

Item	Factor								
	CPWS	CEXP	SN	VOL	CEXP	CEWP	UI	CX	RA
RA1	<b>0.767</b>	0.348	0.254	0.140	0.236	0.320	0.512	0.418	0.660
RA2	0.718	0.275	0.268	0.133	0.197	0.268	0.468	0.440	<b>0.806</b>
RA3	0.719	0.302	0.328	0.125	0.201	0.334	0.524	0.391	<b>0.731</b>
UI1	0.623	0.554	0.073	0.273	0.274	0.226	<b>0.920</b>	0.526	0.236
UI2	0.618	0.619	0.033	0.315	0.292	0.295	<b>0.979</b>	0.519	0.314
UI3	0.601	0.620	0.015	0.293	0.349	0.262	<b>0.949</b>	0.518	0.236
Vol1	0.219	0.184	-0.083	<b>0.870</b>	0.079	-0.042	0.341	0.294	0.081
Vol2	0.160	0.116	0.009	<b>0.874</b>	0.054	-0.002	0.255	0.168	0.038
Vol3	0.080	0.141	-0.059	<b>0.893</b>	0.032	-0.022	0.238	0.143	0.045
CX1	0.366	0.401	-0.015	0.174	0.183	0.200	0.394	<b>0.695</b>	0.195
CX2	0.433	0.456	-0.089	0.243	0.190	0.144	0.571	<b>0.932</b>	0.278
CEXP1	0.182	0.308	-0.157	0.023	<b>0.706</b>	0.312	0.228	0.169	0.090
CTEXP2	0.267	0.388	-0.200	0.060	<b>0.996</b>	0.339	0.297	0.198	0.067
CTEXP3	0.177	0.243	-0.161	0.042	<b>0.736</b>	0.290	0.205	0.153	0.063
CTEWP2	0.441	0.409	0.024	-0.013	0.393	<b>0.944</b>	0.285	0.233	0.108
CTEWP3	0.414	0.357	0.048	-0.018	0.358	<b>0.944</b>	0.248	0.212	0.136
CTVAL1	0.287	<b>0.778</b>	-0.214	0.060	0.398	0.418	0.500	0.404	0.066
CTVAL2	0.288	<b>0.838</b>	-0.145	0.120	0.293	0.329	0.500	0.401	0.112
CTVAL3	0.428	<b>0.912</b>	-0.135	0.150	0.351	0.357	0.601	0.466	0.195
CTVAL4	0.359	<b>0.941</b>	-0.190	0.200	0.361	0.288	0.558	0.414	0.103
CTVAL5	0.326	<b>0.850</b>	-0.218	0.154	0.332	0.318	0.518	0.411	0.115
CTPWS1	<b>0.919</b>	0.357	0.329	0.166	0.261	0.408	0.572	0.422	0.331
CTPWS2	<b>0.949</b>	0.382	0.258	0.145	0.265	0.390	0.595	0.465	0.278
CTPWS3	<b>0.977</b>	0.393	0.292	0.183	0.247	0.430	0.601	0.468	0.295
CTPWS4	<b>0.964</b>	0.331	0.330	0.156	0.220	0.414	0.575	0.430	0.325
SN1	0.409	0.078	<b>0.560</b>	0.169	-0.039	0.115	0.313	0.239	0.192
SN2	0.146	-0.344	<b>0.714</b>	-0.092	-0.240	-0.037	-0.195	-0.133	0.108
SN3	0.287	-0.193	<b>0.977</b>	-0.068	-0.203	0.060	0.002	-0.095	0.177
SN4	0.269	-0.159	<b>0.917</b>	-0.055	-0.183	0.018	0.066	-0.086	0.244



## ABOUT THE AUTHORS

**Craig Van Slyke** is an Associate Professor of Management Information Systems, and Associate Dean for Academic Programs at the John Cook School of Business, Saint Louis University. Prior to becoming Associate Dean, he was chair of the Decision Sciences and IT Management Department. He holds a Ph.D. in Information Systems from the University of South Florida. His research focuses on ICT adoption, particularly in healthcare and e-commerce, and information systems education, focusing on enrollment and curriculum issues. Dr. Van Slyke has published in journals, *Decision Sciences*, *Communications of the ACM*, *Journal of the Association for Information Systems*, *Communications of the Association for Information Systems*, *European Journal of Information Systems*, *Journal of Information Systems Education* and *Information Resources Management Journal*, among others. He serves on the editorial board of *Information Resource Management Journal*, and the *Journal of Information Systems Education*.

**Geoffrey N. Dick** is currently a Professor of Information Systems at North Georgia College and State University, on leave from his position at UNSW. He has been on the board of the AIS SIG Ed for most of the last ten years, three times elected president. He is a reviewer on the global textbooks project, a Director of the International Telework Academy and a screening editor for the *Journal of Information and Management*. His research (around seventy publications) is mainly in the areas of telecommuting (his Ph.D.) and online education—he is the recipient of an ICIS prize for best paper in education and was recently awarded the Emerald Management Review Citation of Excellence for one of fifty best papers worldwide in 2009 published in the top 400 business journals. He is a visiting professor at Georgia Southern and recently has been a visiting fellow at the University of Malaya, the Tec de Monterrey in Mexico and Agder University College, Norway.

**Thomas Case** is Professor and Chair of the Department of Information Systems at Georgia Southern University. He serves on the editorial boards of the *Journal of IS Education (JISE)*, the *Journal of Informatics Education Research (JIER)*, and *Communications of the Association for Information Systems (CAIS)*. He has authored three textbooks and has published extensively on information systems education for more than two decades. His most recent research interests have focused on the characteristics, capabilities, and determinants of the effectiveness of HRIS, talent management, and e-learning systems.

**Virginia Ilie** is an Assistant Professor in the College of Communication and Information at Florida State University. She holds a Ph.D. in Information Systems and an MBA in Finance from the University of Central Florida. Currently, her research interests are in the area of information technology implementation in healthcare organizations, including individual acceptance of clinical information systems. Dr. Ilie's work has appeared in journals such as *Decision Sciences*, *European Journal of Information Systems*, *Database*, and *International Journal of Health Information Systems and Informatics*. She obtained two best papers awards at the Americas Conference in Information Systems (AMCIS 2001) and the International Conference in Information Systems (ICIS 2009).

Copyright © 2010 by the Association for Information Systems. Permission to make digital or hard copies of all or part of this work for personal or classroom use is granted without fee provided that copies are not made or distributed for profit or commercial advantage and that copies bear this notice and full citation on the first page. Copyright for components of this work owned by others than the Association for Information Systems must be honored. Abstracting with credit is permitted. To copy otherwise, to republish, to post on servers, or to redistribute to lists requires prior specific permission and/or fee. Request permission to publish from: AIS Administrative Office, P.O. Box 2712 Atlanta, GA, 30301-2712, Attn: Reprints; or via e-mail from [ais@aisnet.org](mailto:ais@aisnet.org).



# Communications of the Association for Information Systems

ISSN: 1529-3181

**EDITOR-IN-CHIEF**  
Ilze Zigurs  
University of Nebraska at Omaha

## AIS SENIOR EDITORIAL BOARD

Guy Fitzgerald Vice President Publications Brunel University	Ilze Zigurs Editor, <i>CAIS</i> University of Nebraska at Omaha	Kalle Lyytinen Editor, <i>JAIS</i> Case Western Reserve University
Edward A. Stohr Editor-at-Large Stevens Institute of Technology	Blake Ives Editor, Electronic Publications University of Houston	Paul Gray Founding Editor, <i>CAIS</i> Claremont Graduate University

## CAIS ADVISORY BOARD

Gordon Davis University of Minnesota	Ken Kraemer University of California at Irvine	M. Lynne Markus Bentley University	Richard Mason Southern Methodist University
Jay Nunamaker University of Arizona	Henk Sol University of Groningen	Ralph Sprague University of Hawaii	Hugh J. Watson University of Georgia

## CAIS SENIOR EDITORS

Steve Alter University of San Francisco	Jane Fedorowicz Bentley University	Jerry Luftman Stevens Institute of Technology
--	---------------------------------------	--

## CAIS EDITORIAL BOARD

Monica Adya Marquette University	Michel Avital University of Amsterdam	Dinesh Batra Florida International University	Indranil Bose University of Hong Kong
Thomas Case Georgia Southern University	Evan Duggan University of the West Indies	Sy Goodman Georgia Institute of Technology	Mary Granger George Washington University
Ake Gronlund University of Umea	Douglas Havelka Miami University	K.D. Joshi Washington State University	Michel Kalika University of Paris Dauphine
Karlheinz Kautz Copenhagen Business School	Julie Kendall Rutgers University	Nancy Lankton Marshall University	Claudia Loebbecke University of Cologne
Paul Benjamin Lowry Brigham Young University	Sal March Vanderbilt University	Don McCubbrey University of Denver	Fred Niederman St. Louis University
Shan Ling Pan National University of Singapore	Katia Passerini New Jersey Institute of Technology	Jackie Rees Purdue University	Thompson Teo National University of Singapore
Chelley Vician University of St. Thomas	Padmal Vitharana Syracuse University	Rolf Wigand University of Arkansas, Little Rock	A.B.J.M. (Fons) Wijnhoven University of Twente
Vance Wilson Worcester Polytechnic Institute	Peter Wolcott University of Nebraska at Omaha	Yajiong Xue East Carolina University	

## DEPARTMENTS

Global Diffusion of the Internet Editors: Peter Wolcott and Sy Goodman	Information Technology and Systems Editors: Sal March and Dinesh Batra
Papers in French Editor: Michel Kalika	Information Systems and Healthcare Editor: Vance Wilson

## ADMINISTRATIVE PERSONNEL

James P. Tinsley AIS Executive Director	Vipin Arora CAIS Managing Editor University of Nebraska at Omaha	Sheri Hronek CAIS Publications Editor Hronek Associates, Inc.	Copyediting by S4Carlisle Publishing Services
--	--	---	--

