

# **A Preliminary Examination of the Factors for Knowledge Sharing in Technology Mediated Learning**

**Yujong Hwang**

School of Accountancy & Management Information Systems

DePaul University

1 E. Jackson Blvd

Chicago, IL 60604 USA

[yhwang1@depaul.edu](mailto:yhwang1@depaul.edu)

## **ABSTRACT**

Affective commitment and intrinsic motivation to share knowledge are important issues in developing successful technology-mediated learning (TML) and knowledge management (KM) systems. This paper investigates an individual's social/self identities and affective commitment as important identity factors for perceived enjoyment to share knowledge by email and knowledge sharing attitude in the TML environment. An empirical test of the proposed model was conducted in the pilot test ( $n = 155$ ) as well as the main test ( $n = 411$ ). Identity factors (social/self identities and affective commitment) influence perceived enjoyment ( $R^2 = 0.52$ ), and perceived enjoyment influences knowledge sharing attitude ( $R^2 = 0.51$ ) in TML. The results of this study will help us understand the antecedents of effective knowledge sharing intervention in the TML environment, based on the integrated model of social identity theory, social influence theory, and self determination theory. Furthermore, information systems practitioners and educators will be able to understand the roles of identity factors in developing and designing TML and KM systems.

**Keywords:** Technology mediated learning, Knowledge sharing attitude, Identity factors, Perceived enjoyment

## **1. INTRODUCTION**

Technology-mediated learning (TML) has been defined as “an environment in which the learner's interactions with learning materials (e.g., readings, assignments, exercises), peers, and/or instructors are mediated through advanced information technologies” (Alavi and Leidner, 2001b, p.2). Since mandatory involvement requirements may not intrinsically motivate learners to achieve high quality learning (Bullen, 1998), affective commitment, psychological attachment mechanism such as identification and internalization, is an especially important determinant of TML success. Thus, affective commitment and intrinsic motivation to share knowledge are critical issues in developing successful TML and knowledge management (KM) systems. In addition, social intervention for interaction and communication in e-learning positively influence outcomes in varied dimensions of TML (Rourke and Anderson, 2002; Garrison et al., 2003; Baugher et al., 2003; Gallardo et al., 2007; Ellis, 2007). Given that effective learning requires engagement with others in the learning community (Laurillard, 2000; Rungtusanatham et al., 2004; Janicki & Steinberg, 2003; Antony and Santhanam, 2007; Bullen, 1998), these social factors should be investigated further in the TML context. Bohlken (1998) suggested that incorporating the social aspects of e-learning can enhance classroom effectiveness within a TML environment. For

example, several studies suggest that in-depth learning effects are accomplished when students realize the need to learn by collaboratively sharing knowledge (Cooney, 2000; Arbaugh, 2000; Poole, 2000; Siau et al., 2006; Hopgood and Hirst, 2007).

Knowledge sharing has been an important variable in the TML and KM literature incorporating social factors (e.g., Alavi et al., 2006; Alavi and Leidner, 2001a; Bock et al., 2005; Ko et al., 2005; Wasko & Faraj, 2005; Chiu et al., 2007; Powell et al., 2007). Despite the availability of the best technologies and rich information in the knowledge organization, KM system users' motivation and commitment to sharing knowledge in the organization often determine the success or failure of KM systems (Dyer and McDonough, 2001; Malhotra and Galletta, 2003). For example, a simple system for “knowledge sharing” that was sent out with questions and email invitations to potential participants failed, without even a single user posting any message after six months (Charles, 2002). In the TML systems context, peer participation can influence the student's attitude and action toward knowledge sharing (Piccoli et al., 2001). Janz and Prasarnphanich (2003) explained the relationships among organizational climate, the level of cooperative learning that takes place between knowledge workers, and the resulting level of knowledge created by team performance and individual satisfaction levels.

Based on insights into the social factors of knowledge sharing behavior, the role of affective commitment, such as identification (relationships established and maintained among group members), for the proactive adoption of KM or TML systems is recently gaining significant interest from IS and KM researchers (e.g., Venkatesh and Speier, 2000; Malhotra and Galletta, 2005; Alavi and Leidner, 2001a). Malhotra and Galletta (2005) argued that a system user's affective commitment development was omitted in the previous research model which investigated IS adoption in the IS and KM literature. Malhotra and Galletta (2003, 2005) argued that previous KM literature focused on commitment by compliance (to gain extrinsic reward), which makes our understanding of social influence, such as social identity and self identity, and knowledge sharing behavior incomplete. Thus, this paper investigates several psychological variables that have been recently introduced into the IS and KM literature, which enables us to more fully understand the important factors and dynamic relationships involved in knowledge sharing in the TML environment.

In this study, social identity and self identity are hypothesized as direct antecedents to the system users' (or learners') perceived enjoyment in sharing knowledge by email. Given that committed and voluntary email communication to share knowledge is the crucial factor for TML and KM success, these relationships are important. The direct effects of social identity and self identity on perceived enjoyment toward sharing knowledge by email would be tested and compared to the effect of an affective commitment. This study's results will clearly demonstrate the role of affective commitment and social and self identities in improving intrinsic motivation to share knowledge by email in the TML environment. In this study, knowledge sharing in the TML environment should be interpreted as a voluntary system because the learners can freely choose the communication media, such as group email function of Blackboard class management system, telephone, or face-to-face discussion, and there is no instructor's intervention in this knowledge sharing process. Although the students in the study are provided with the group email system in Blackboard, they can also use the alternative communication media in the classroom or home, making email usage for knowledge sharing to be voluntary.

The organization of this paper is as follows: Section 2 presents the theoretical foundations of this research model and the hypotheses. Section 3 outlines the research methodology and measures. Section 4 describes the data analysis and results. Section 5 then discusses implications for researchers and practitioners and concludes the paper.

## **2. LITERATURE REVIEW & HYPOTHESES**

### **2.1. Social/Self Identity and Perceived Enjoyment**

Social identity theory (Tajfel, 1982; Tajfel and Turner, 1986) is concerned with when and why individuals identify with, and behave as part of, social groups, adopting shared attitudes towards outsiders. Tajfel (1982) sought an account of group identity that held together both society and the individual. Tajfel first sought to differentiate between those elements of self identity derived from individual personality traits and interpersonal relationships as opposed to those

elements of social identity derived from belonging to a particular group. Social identity is defined as the individual's knowledge that he/she belongs to certain social groups, together with some emotional and value significance to him/her of the group membership (Abrams and Hogg, 1990). Therefore, it is the groups to which we belong that form our social identity or our self conception as a group member. Self identity is defined as the salient part of an actor's self which relates to a particular behavior that reflects the extent to which an actor sees him/herself as fulfilling the criteria for any societal role (Conner and Armitage, 1998). Abrams and Hogg (1990) and Turner (1982) conceptualize self identity as a subsystem of self-concept. Self-concept is described as a collection of images which vary in terms of the length of their establishment, complexity and richness of content. Each individual is seen to have a repertoire of identities open to them (social and self), each identity informing the individual of who he/she is and what this identity entails (Turner, 1982). The salience of these many identities for an individual at any time will vary according to the social context (Abrams and Hogg, 1990). Where self identity is salient, the individual will relate to others in an interpersonal manner, dependent on their character traits and any personal relationship existing between the individuals. However, social identity is more salient than self identity in self-conception when the group behavior is more salient.

Perceived enjoyment refers to the extent to which the activity of using a computer system is perceived to be personally enjoyable in its own right aside from the instrumental value of the technology (Davis et al., 1992; Yi and Hwang, 2003; Hwang, 2005). According to Davis et al. (1992, p. 1112), extrinsic motivation refers to "the performance of an activity because it is perceived to be instrumental in achieving valued outcomes that are distinct from the activity itself," whereas intrinsic motivation refers to "the performance of an activity for no apparent reinforcement other than the process of performing the activity per se." Davis et al. (1992) and Venkatesh and Speier (2000) classified enjoyment as a type of intrinsic motivation and perceived usefulness as a type of extrinsic motivation. Several studies of flow theory showed the relationship between perceived enjoyment and perceived control, that is, the extent to which a user feels in charge of the interaction (Ghani and Deshpande, 1994; Ghani et al., 1991; Webster and Ho, 1997; Chan, 2001; Chung and Tan, 2004). Flow construct includes intense concentration, a sense of being in control, a loss of self-consciousness and a transformation of time (Agarwal and Karahana, 2000). This shows that perceived enjoyment or flow enhances the perceived control that is mainly governed by self, which can be interpreted as self control within a voluntary context.

Self determination theory (Deci and Ryan, 1985) showed that all individuals have natural, innate, and constructive tendencies to develop an ever more elaborate and unified sense of self. It focuses on how individuals develop a coherent sense of self through regulation of their behavioral actions that may be self-determined, controlled, or motivated. Malhotra (2002) argued that tacit perspective of knowledge management should be managed and controlled mainly by self control or intrinsic motivation, rather than by formal controls based on self determination

theory. Based on social identity theory and self determination theory, we hypothesize that both social and self identities influence perceived enjoyment of sharing knowledge by email within a voluntary system environment of TML. Given that thinking of ourselves as a group member (social identity) and thinking of myself as a unique individual (self identity) are both important determinants of self, these aspects should influence the self control or perceived enjoyment to share knowledge by email. Terry et al. (1999) suggested that social identity influences the intrinsic motivation or attitude of the recycling behavior of community residents. Self identity has also been considered to be related to an intrinsic motivation for human behavior, since there is no apparent reinforcement other than one's own internal needs (Compeau and Higgins, 1995; Lee et al., 2001). Thus, we hypothesize that;

*H1: Self Identity will have a positive effect on Perceived Enjoyment of Sharing Knowledge by email.*

*H2: Social Identity will have a positive effect on Perceived Enjoyment of Sharing Knowledge by email.*

### **2.1. Affective Commitment and Attitude**

Social influence theory (Kelman, 1958, 1961) provides a well-established basis for understanding social behavior of individuals that relates to identities. Social influence theory distinguishes a variety of types and levels of social commitment: identification, internalization and compliance. Kelman's theory explains how the different commitment mechanisms change the target behavior. For example, identification occurs when system users adopt behaviors to achieve a satisfying and self-defining relationship with another person or group. Internalization occurs when system users adopt behavior because of its content, which they find congruent with their own values. These two mechanisms, explained as "affective commitment" by Malhotra and Galletta (2005), alter an individual's belief structure, causing an individual to respond to potential social status gain. The third mechanism of commitment is compliance, which occurs when the behavior is primarily a result of incentives, rewards, or punishments, but the actor may not necessarily appreciate or understand the value of the desired behavior. Compliance can result in behavior modification only if the actor's behavior is controlled and managed by organizational intervention. Based on Kelman's (1958, 1961) social influence theory, Venkatesh and Davis (2000) suggested that compliance in mandatory contexts causes social influence to have a direct effect on intention; in contrast, social influence in voluntary contexts operates by influencing perception about the technology through the psychological attachment mechanisms of affective commitment, such as identification and internalization. Identification occurs when a person interacts with others to achieve a satisfying and self-defining relationship with another person or group (Kelman, 1958, 1961). We identify with groups to which we perceive ourselves as belonging.

This study tests the influence of affective commitment (identification) on perceived enjoyment of sharing knowledge by email. Since identification process derives from system user's affective commitment, it focuses on a satisfying self-defining relationship with another person or

group or an intrinsic motivation of group behavior. In identification, the system user's feeling of satisfaction derived from the salience of the desired relationship has a similar effect on intrinsic motivation (Malhotra and Galletta, 2005; O'Reilly and Chatman, 1986). Lewis et al. (2003) explained (p. 662), "Via identification, the individual seeks to believe and act in a manner similar to those possessing referent powers. Therefore, compelling messages received from important others are likely to influence one's cognition about the expected outcomes of technology use." Specifically, in the TML or KM systems environment, this group salience or relationship, through affective commitment by identification, plays an important role in developing perceived enjoyment to share knowledge by email. Thus, we hypothesize that;

*H3: Affective Commitment will have a positive effect on Perceived Enjoyment of Sharing Knowledge by email.*

Attitude is defined as "a learned predisposition to response in a consistently favorable or unfavorable manner with respect to a given object" (Fishbein and Ajzen 1975, p. 6). Based on social influence theory (Kelman, 1958), social influence in voluntary contexts operates by influencing attitude to the technology through the psychological attachment mechanisms of affective commitment, such as identification. Terry et al. (1999) also suggested that the relationship between the intrinsic motivation and attitude of the recycling behavior of community residents. Sun and Zhang (2006) argued that there are several marketing studies that show affective reaction, such as emotion or enjoyment, influences cognitive perceptions or behavioral attitude. Mattila and Wirtz (2000) also showed that consumer's initial affective reaction leads them to mood consistent information, which is related to behavioral attitude. Perceived enjoyment influences various aspects of cognitive information processing attitude (Dube et al., 2000) and cognitive beliefs (Hwang, 2005). These findings suggest that there is a potential relationship between perceived enjoyment and attitude. Attitude has been an important variable in the various psychological models such as technology acceptance model (Davis, 1989) and theory of reasoned action (Fishbein and Ajzen 1975). Given the importance of empirical relationship of the current model with the technology acceptance model and theory of reasoned action, we hypothesize that;

*H4: Perceived Enjoyment of Sharing Knowledge by email will have a positive effect on Attitude of Knowledge Sharing by TML.*

Figure 1 presents the proposed research model based on the previous literature review and hypotheses. This study includes self identity, social identity, and affective commitment in the model as identity factors for perceived enjoyment and attitude of sharing knowledge by email in TML. These three constructs are categorized as the identity factors because they influence intrinsic motivation based on the causality logic of the constructs (Pearl, 2000). Furthermore, this study tests the relationship between perceived enjoyment and attitude based on social influence theory.

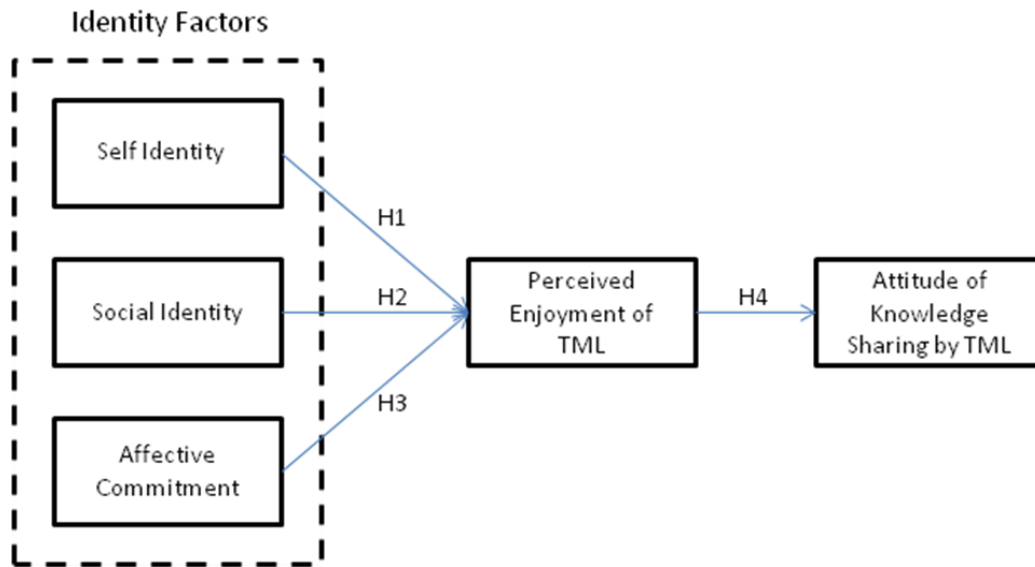

Figure 1. Proposed Research Model

### 3. METHOD & MEASURES

A survey of undergraduate business students in the northern region of the U.S. was implemented with the students who were in the introductory MIS course and voluntarily participated in the survey. The students were asked to show their opinions and perceptions regarding knowledge sharing by group email functions in Blackboard, the Internet-based academic class management system. Each group in the class was composed of four members and was assigned to prepare two group projects for final presentation in the course. One of the group projects was a structured interview with IT experts in the field regarding IS job market issues and a recently completed IS project management engagement. Group members were required to complete the group's work, such as interviewing, preparing an interview protocol, reporting and presenting, and to participate in the project via group emails, telephone, and face-to-face discussion in class. The second group project was a database development project using MS Access. Each group was required to develop a CD management database using seven tables and relationships in MS Access. Overall database structure was to be decided based on the discussion of group members. These two projects are managed among the same group with the group email function in Blackboard. Our focus on this paper is the email usage in Blackboard although there are new approaches of communication, such as instant messaging or online discussion board (Alavi and Leidner, 2001), in the class management systems. Given that previous research, such as Antony and Santhanam (2007), has focused on email usage in knowledge sharing context, our focus is on email usage in Blackboard to share their knowledge for the better performance in the group project.

We developed an online survey website and posted this URL to the "Announcement" menu of Blackboard for the students to access for two weeks. The online survey was conducted after the two group projects are completed. As there are four group members in each group, we should ask

to complete two different projects to encourage them to cooperate and use group email function in Blackboard. We have requested the students to participate in the online survey after finishing two group projects, because this experience would be necessary to respond to the questions in the survey. In the pilot test with 155 participants, we reworded some items and collected the valid items with more than 0.70 composite reliability (Cronbach's alpha) and more than 0.50 item-to-total correlations using SPSS (see the Appendix 1 for the detailed items and reliabilities in the pilot test). Based on the pilot test results with these criteria (Moore and Benbasat, 1991), we kept all items in the pilot test. In the main test, an additional 411 students, all of whom were not pilot test participants, voluntarily participated in the study. The average age of participants was 21.72 years, and 52% were male. Seventy six percent of participants reported currently having a full-time or part-time job (see Table 1 for the sample demographics). All of these participants are from the same institution. After introducing group email function in Blackboard in the beginning of the course, the student survey via online survey system was conducted in the sixth

Demographics		Respondents
Age		Average: 21.72 years (Standard Deviation: 2.23 years)
Gender	Male	211 (52%)
	Female	200 (48%)
Currently Employed	Yes	312 (76%)
	No	99 (24%)

Table 1. Sample Demographics (n=411)

and seventh weeks of the course. There was no difference of the results between the earlier participants (sixth week) and the later participants (seventh week) in the survey, showing that non-response bias was not an issue.

Most of the measurement items are adapted and revised from previous research, as we explained in the hypotheses section (see the detailed items in the Appendix 1). All questionnaire items used a 5-point Likert-type scale where 1 = completely disagree, 3 = neither agree nor disagree, and 5 = completely agree. Three items adapted from Ashforth et al. (1998) and Mael and Tetrick (1992) were revised for the TML context to measure social identity. Three items adapted from Sparks and Shepard (1992) and Charmg et al. (1988) were revised for the TML context to measure self identity. Three items adapted from Malhotra and Galletta (2005) were used to measure identification of sharing knowledge by email. Perceived enjoyment and attitude of sharing knowledge by email was measured by three and four items adapted from Davis et al. (1992).

**4. DATA ANALYSIS & RESULTS**

Measure validation and model testing were conducted using Partial Least Square (PLS) Graph Version 3.0 (Chin & Frye, 1998), a structural equation-modeling (SEM) tool that utilizes a component-based approach to estimation. PLS makes few assumptions about measurement scales, sample size, and distributional assumptions (Chin, 1998; Falk & Miller, 1992; Fornell & Bookstein, 1982; Wold, 1982). Compared with covariance-based SEM tools such as LISREL and EQS, PLS is more appropriate for exploratory research into new phenomena with the complex model, which is the case in our study (Chin, 1998). This study, which includes both direct and moderating effects in the complex model, used PLS rather than the other SEM techniques in data analysis. Chin (1998, p. 311) advises that “if one were to use a regression heuristic of 10 cases per indicator,” the sample size requirement would be 10 times (1) the largest number of formative indicators or (2) the largest number of independent variables impacting a dependent variable, whichever is the greater. In our model, all items are modeled as reflective indicators because they are viewed as effects (not causes) of latent variables (Barclay et al., 1995). The largest number of independent variables estimated for a dependent variable is only three. Thus, our

sample size of 411 is more than adequate for the PLS estimation procedures.

**4.1. Psychometric Properties of Measures**

Before testing the hypothesized structural model, we first evaluated the psychometric properties of the study variables through confirmatory factor analysis using a measurement model in which the first-order latent variables were specified as correlated variables with no causal paths. The measurement model was assessed by using PLS to examine internal consistency reliability and convergent and discriminant validity (Barclay et al., 1995; Chin, 1998; Yi & Davis, 2003). Internal consistencies of 0.7 or higher are considered adequate. Two criteria are generally applied to assess convergent and discriminant validity: (1) the square root of the average variance extracted (AVE) by a construct should be at least 0.707 (i.e., AVE > 0.50) and should exceed that construct’s correlation with other constructs, and (2) item loadings should be at least 0.707 and an item should load more highly on the one it is intended to measure than on any other construct.

Table 2 shows internal consistency reliabilities, convergent and discriminant validities, and correlations among latent constructs. All five internal consistency reliabilities exceeded the minimal reliability criteria (0.7). Also, satisfying convergent and discriminant validity criteria, (1) the square root of the AVE was greater than 0.707 and greater than the correlation between that construct and other constructs, and (2) the factor structure matrix (Table 3) shows that items exhibited high loadings (>0.707) on their respective constructs, and no items loaded higher on constructs that they were not intended to measure. Collectively, the psychometric properties of the study variables were considered relevant and sufficiently strong to support valid testing of the proposed structural model.

**4.2. Test of Model and Hypotheses**

The PLS structural model and hypotheses were assessed by examining path coefficients and their significance levels. Following Chin (1998), bootstrapping (with 500 resamples) was performed on the model to obtain estimates of standard errors for testing the statistical significance of path coefficients using a t-test. Figure 2 provides the results of hypothesis testing. All direct paths in the model (Hypotheses 1-4) were supported within the 0.001 significance level.

Construct	AVG	S.D.	ICR	Social Identity	Self Identity	Identification	Enjoyment	Attitude
Social Identity	3.38	1.10	<b>0.88</b>	<b>0.85</b>				
Self Identity	3.40	1.07	<b>0.89</b>	0.62	<b>0.85</b>			
Identification	3.35	1.08	<b>0.88</b>	0.60	0.56	<b>0.84</b>		
Enjoyment	3.41	0.99	<b>0.92</b>	0.56	0.56	0.68	<b>0.89</b>	
Attitude	3.34	1.01	<b>0.90</b>	0.56	0.62	0.65	0.71	<b>0.84</b>

*Note.* Internal Consistency Reliability (ICR) should be larger than 0.70. Diagonal element is the square roots of AVE and should be larger than the off-diagonal and >0.707 for the convergent and discriminant validities. All the constructs are on a scale of 1 (negative) to 5 (positive).

**Table 2. Internal Consistencies and Correlations of Constructs (n=411)**

Scale Items	Self Identity	Social Identity	Identification	Enjoyment	Attitude
Self Identity1	<b>0.88</b>	0.61	0.54	0.50	0.52
Self Identity2	<b>0.86</b>	0.47	0.47	0.49	0.51
Self Identity3	<b>0.83</b>	0.50	0.42	0.46	0.49
Social Identity1	0.42	<b>0.76</b>	0.45	0.46	0.48
Social Identity2	0.55	<b>0.89</b>	0.52	0.48	0.50
Social Identity3	0.60	<b>0.89</b>	0.54	0.49	0.52
Identification1	0.49	0.52	<b>0.84</b>	0.58	0.53
Identification2	0.50	0.55	<b>0.87</b>	0.58	0.57
Identification3	0.42	0.44	<b>0.80</b>	0.53	0.54
Enjoyment1	0.50	0.49	0.61	<b>0.91</b>	0.60
Enjoyment2	0.50	0.50	0.58	<b>0.89</b>	0.57
Enjoyment3	0.52	0.52	0.62	<b>0.89</b>	0.55
Attitude1	0.55	0.49	0.54	0.57	<b>0.81</b>
Attitude2	0.52	0.54	0.55	0.55	<b>0.85</b>
Attitude3	0.50	0.52	0.54	0.54	<b>0.88</b>
Attitude4	0.48	0.52	0.50	0.56	<b>0.79</b>

Table 3. Factor Structure Matrix of Loadings and Cross-Loadings (n=411)

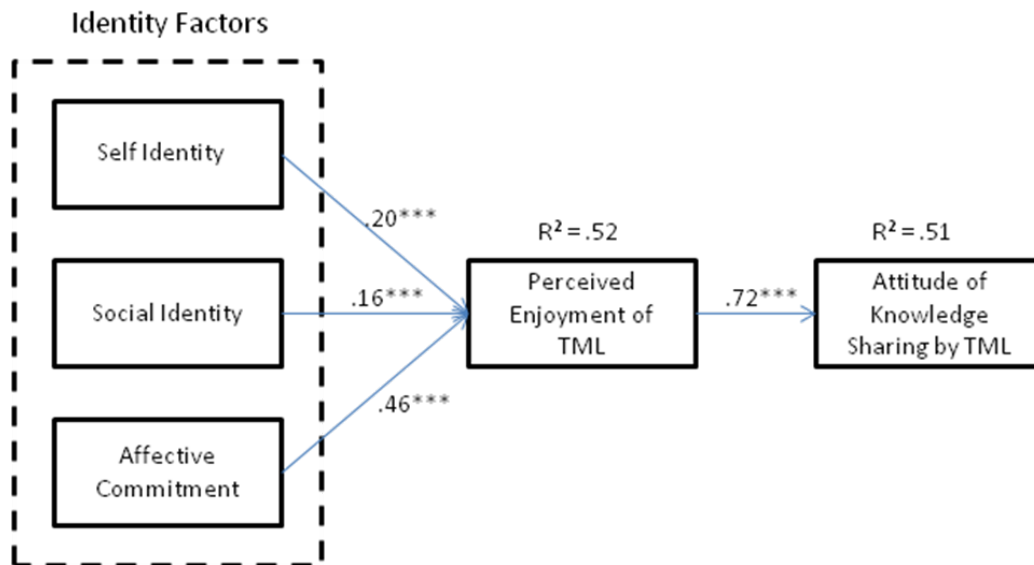

Figure 2. PLS Test Results (n = 411)

## 5. DISCUSSION

### 5.1. Summary

There are several studies that show the knowledge sharing on the electronic communication media is an effective teaching intervention in the TML. For example, Hopgood and Hirst (2007) found that a clear majority of students favored the usage of the electronic study guide in the class management systems, particularly for the teaching genetic algorithms, where the interactivity enabled difficult concepts to be demonstrated in a way that would not be possible on the printed page. Siau et al. (2006) also reported on the use of a classroom response system

to enhance classroom interactivity in a system analysis and design course. This previous literature on TML shows that knowledge sharing by electronic media is very important component in the TML context.

This study has developed and tested a new model that theorizes two constructs of identity -- social identity and self identity -- and affective commitment as significant identity factors for perceived enjoyment based on social identity theory (Tajfel, 1982). Further, the relationship between perceived enjoyment and attitude has been tested based on social influence theory (Kelman, 1958, 1961). These relationships are also supported by the self determination theory (Deci and Ryan,

1985) in that knowledge sharing in the group is mainly related to the intrinsic motivation. With only three variables of identities and affective commitment, the model explains 52% of perceived enjoyment and 51% of attitude of sharing knowledge by email in TML, which is a considerably high explanatory power for complex knowledge sharing behavior. All four hypotheses were supported, justifying high confidence in the model. Overall, the proposed model is well supported by the data and provides a new and theoretical explanation of how different identities and identification contribute to a learner's intrinsic motivation to share knowledge by email in TML.

As we showed in the empirical findings of the data analysis, intrinsic motivation to share knowledge by email is changed and developed through identification and social and self identities. Given that intrinsic motivation to share knowledge by email is crucial to the success of TML and KM implementation (Deci and Ryan, 1985; Bock et al., 2005), the development of this motivation is a very important research issue to the IS community. As TML and KM usually depend on a voluntary system adoption environment, the positive and significant effects of identities on perceived enjoyment provide initial empirical evidence to establish the linkage between affective commitment (identification) and TML and KM effectiveness. Assuming that reluctance to share knowledge is the main reasons for the failure of TML and KM systems (Alavi et al., 2006), the model provides a valuable explanation of how different identities influence knowledge sharers' intrinsic motivation. The framework provided by affective commitment (identification) and the different identities helps reduce the gap between identity specific activities and psychological attachment in TML and KM.

### **5.2. Limitations**

Some limitations of the present study should be noted. First, it is unknown how well the model and its findings will generalize beyond the specific conditions of this study, since we used one university's students as a sample. Future work is needed to understand how well the new model generalizes to TML and KM systems adopters with different backgrounds. For example, future research can extend this model to the other types of samples such as working environment or graduate students with more experience of TML to enhance the generalizability of the model. Second, we did not include the other affective commitment variable in the social influence theory: internalization. However, this study focuses on identification and identities, suggesting that the internalized behavior is outside the main research question of this study. Future study should investigate this dimension further to make our knowledge more complete. Finally, the current study did not include other possible moderating variables, such as experience and gender, in the model. Given that experience and gender is an important aspect of knowledge sharing and communication behavior (Tannen, 1991), we argue these should be investigated further. Future study can test the relationships with other moderating variables.

### **5.3. Implications for Practice and Research**

The practical contribution of this research is to show important aspects of affective for knowledge sharing in TML and KM systems implementation, applying the social influence theory by Kelman (1958, 1961). The relationships among social identity,

self identity, and perceived enjoyment of sharing knowledge, suggested and confirmed by this study, can be used to target activities needed to further improve TML or KM implementation. It has been emphasized that further research in IS should attempt to bridge the gap between the information-based model of the organization and the knowledge-based view that recognizes diverse perspectives, values, and attitudes of KM and TML adopters (Zack, 2001). For example, KM or TML system designers can focus on satisfying group relationships among voluntary users to facilitate knowledge sharing by incorporating various approaches such as "knowledge repositories" or "communities of practice" (DeLone and McLean, 2003).

Identification of knowledge contributors is the most important factor for system success, specifically when the contributors believe the group is important to themselves. This identification of knowledge contributors is a more powerful factor for knowledge sharing than the other normative or mandate factors. Furthermore, intrinsic motivation in the TML contexts can be developed through the game based learning applications. For example, game portal website is one of good benchmarking example for the TML community development. Social networking functions in the game portal website can be applied to the TML contexts based on the findings in the current study. Our proposed model supports the overall understanding of these phenomena, based on our empirical findings. Given that much current IS research focuses on knowledge sharing (e.g., Ko et al., 2005; Wasko & Faraj, 2005; Bock et al., 2005; Goo et al., 2007), the present study shows that the effects of identities and affective commitment are crucial to improving the "enjoy-ability" factor in KM and TML systems. As the empirical results in this study show, there are significant effects of social and self identities in these relationships. For example, "communities of practice" (DeLone and McLean, 2003) in KM and TML would be more successful with inter-social group members because of the strong relationship between social identity and perceived enjoyment. These findings also provide further practical guidance in developing and designing KM and TML systems.

Further research is also needed to specifically examine the influences of other individual characteristic constructs on social identity, self identity, identification, and intrinsic motivation to share knowledge by email. Given the strong relationship between perceived enjoyment and attitude of knowledge sharing by TML, the other important psychological models, such as technology acceptance model and theory of reasoned action can be linked and tested further in the future research. The relationships among other constructs, such as culture, capability, and extrinsic motivation, and different identities also deserve exploration. Further, how these psychological constructs are related to actual learning performance should be investigated further in future research.

## **6. CONCLUSION**

In conclusion, knowledge sharing by email is a fundamental driver of TML and KM success. The present research establishes an empirical link among different identities, affective commitment, and perceived enjoyment as well as attitude, representing an important initial step toward understanding social and psychological interpretation of

technology-mediated knowledge sharing behavior. Given the importance of attitude construct in the psychological models, the relationship between perceived enjoyment (intrinsic motivation) and attitude of knowledge sharing by TML is the advanced theoretical application and new finding in this study. This paper provides the new link and opens the door to the advance of social factors and TML based on the social identity theory, social influence theory, and self-determination theory. We argue that the integration of these models in the current paper with empirical tests is unique and important contribution to the IS and TML fields. Our model and findings should help TML and KM systems designers, educators, and adopters understand who most enjoys sharing their own valuable knowledge by email with the complex identities.

## REFERENCES

- Abrams, D., & Hogg, M. A., (1990) "An introduction to the social identity approach," in *Social Identity Theory: Constructive and Critical Advances*, Abrams and Hogg, M. A. (eds.), New York: Springer-Verlag, pp. 1-27.
- Agarwal, R. & Karahanna, E., (2000) "Time flies when you're having fun: Cognitive absorption and beliefs about information technology use," *MIS Quarterly*, (24: 4), pp. 665-694.
- Alavi, M., Kayworth, T. R., & Leidner, D. E., (2006) "An empirical examination of the influence of organizational culture on knowledge management practices," *Journal of MIS*, (22:3), pp. 191-224.
- Alavi, M., and Leidner, D. E. (2001a) "Knowledge management and knowledge management systems: Conceptual foundations and research issues," *MIS Quarterly*, (25:1), pp. 107-136.
- Alavi, M., and Leidner, D. E. (2001b) "Technology mediated learning: A call for greater depth and breadth of research," *Information Systems Research* (12:1), pp. 1-10.
- Antony, S., & Santhanam, R., (2007) "Could the use of a knowledge-based system lead to implicit learning?" *Decision Support Systems*, (43: 1), pp. 141-151.
- Arbaugh, J.B., (2000) "Virtual classroom characteristics and student satisfaction with internet-based MBA courses," *Journal of Management Education*, (24: 1), pp. 32-54.
- Ashforth, B. E., Saks, A. M., & Lee, R. T., (1998) "Socialization and newcomer adjustment: The role of organizational context," *Human Relations*, (51), pp. 897-926.
- Barclay, D., Higgins, C., & Thompson, R., (1995) "The partial least square approach to causal modeling: Personal computer adoption and use as an illustration," *Technology Study*, (2), pp. 285-309.
- Baughar, D., Varanelli, A., & Weisbord, E., (2003) "Student hits in an Internet-supported course: How can instructors use them and what do they mean?" *Decision Sciences Journal of Innovative Education*, (1: 2), pp. 159-179.
- Bock, G., R., Zmund, W., Kim, Y. G., Lee, J. (2005) "Behavioral intention formation in knowledge sharing: Examining the roles of extrinsic motivators, social-psychological forces and organizational climate," *MIS Quarterly* (29:1), pp. 87-111.
- Bohlken, B., (1998) "Reciprocal listening with and from the heart in the electronic classroom," *Proceedings of Annual Meeting of the International Listening Association*, Kansas City.
- Bullen, M., (1998) "Participation and critical thinking in online university distance education," *Journal of Distance Education*, 1998, pp. 1-32.
- Chan, C.Y.N., (2001) *An Empirical Investigation of Interactivity and Consumer Online Experience in Hypermedia Computer-mediated Environments*, University of Auckland.
- Charles, S. K., (2002) "Knowledge management lessons from the document trenches," *Online*, (26:1), pp. 22-29.
- Charny, H. W., Bank, B. J., & Callero, P. L., (1988) "Role identity and reasoned action in the prediction of repeated behavior," *Social Psychology Quarterly*, (51), pp. 303-317.
- Chin, W. W. (1998) "The partial least squares approach to structural equation modeling", in *Modern Methods for Business Research*. Marcoulides, G. A., (Ed.), Lawrence Erlbaum Associates, Mahwah, NJ, pp. 195-336.
- Chin, W. W., & Frye, T. A. (1998) PLS-Graph, Version 3.0.
- Chiu, C., Hsu, M., & Wang, E., (2007) "Understanding knowledge sharing in virtual communities: An integration of social capital and social cognitive theories," *Decision Support Systems*, (42: 3), pp. 1872-1888.
- Chung, J. & Tan, F. B., (2001) "Antecedents of perceived playfulness: An exploratory study on user acceptance of general information-searching websites," *Information and Management*, (41), pp. 869-881.
- Compeau, D. R., & Higgins, C. A., (1995) "Computer self-efficacy: Development of a measure and initial test," *MIS Quarterly*, (19: 2), pp. 189-211.
- Conner, M. and Armitage, C. (1998) "Extending the theory of planned behavior: a review and avenues for further research," *Journal of Applied Social Psychology*, (28), pp. 1429-1464.
- Cooney, D.H., (2000) "Sharing aspects within aspects: Real time collaboration in the high school English classroom," in Abbey, B. (Ed.) *Instructional and Cognitive Impacts of Web-based Education*, Idea Publishing Group, Hershey, PA. pp.263-287.
- Davis, F. D. (1989) "Perceived usefulness, perceived ease of use, and user acceptance of information technology," *MIS Quarterly* (13:3), pp. 319-340.
- Davis, F. D., Bagozzi, R. P., & Warshaw, P. R., (1992) "Extrinsic and intrinsic motivation to use computers in the workplace," *Journal of Applied Social Psychology*, (22), pp. 1111-1132.
- Deci, E. L. & Ryan, R. M., (1985) *Intrinsic Motivation and Self-determination in Human Behavior*, Plenum, New York.
- DeLone, W. H. & McLean, E. R., (2003) "The DeLone and McLean Model of information systems success: A ten-year update," *Journal of MIS*, (19:4), pp. 9-30.
- Dube, L., Cervellon, C., & Jingyuan, H., (2003) "Should consumer attitudes be reduced to their affective and cognitive bases? Validation of a hierarchical model," *International Journal of Research in Marketing*, (20:3), pp. 259-272.
- Dyer, G., & McDonough, B., (2001) "The state of knowledge management," *Knowledge Management*, (4:5), pp. 31-36.
- Ellis, H. J. C., (2003) "An assessment of a self-directed learning approach in a graduate Web application design and development course," *IEEE Transactions on Education*, (50: 1), pp. 55-60.



- Falk, R. F., & Miller, N. B., (1992) *A Primer for Soft Modeling*, The University of Akron, Akron, OH.
- Fishbein, M., & Ajzen, I. (1975). *Belief, Attitude, Intention, and Behavior: An Introduction to Theory and Research*. Reading, MA: Addison-Wesley.
- Fornell, C., & Bookstein, L., (1982) "The structural equation models: LISREL and PLS applied to consumer exit-voice theory," *Journal of Marketing Research*, (19), pp. 440-452.
- Gallardo, S.; Barrero, F. J.; Martnez-Torres, M. R.; Toral, S. L.; Durn, M. J., (2007) "Addressing learner satisfaction outcomes in electronic instrumentation and measurement laboratory course organization," *IEEE Transactions on Education*, (50: 2), pp. 129-136.
- Garrison, D.R., Anderson, T., & Archer, W., (2003) "A theory of critical inquiry in online distance education," in Moore, M.G. & Anderson, W.G., (Ed.) *Handbook of Distance Education*, Laurence Erlbaum, London, pp. 113-128.
- Ghani, J. & Deshpande, S., (1994) "Task characteristics and the experience of optimal flow in human-computer interaction," *Journal of Psychology*, (128: 4), pp. 381-391.
- Ghani, J., Supnick, R., & Rooney, P., (1991) "The experience of flow in computer-mediated and in face-to-face groups," in *Proceedings of the 12<sup>th</sup> International Conference on Information Systems*, New York.
- Goo, J., Kishore, R., Nam, K., Rao, R., & Song, Y., (2003) "An investigation of factors that influence the duration of IT outsourcing relationships," *Decision Support Systems*, (42: 4), pp. 2107-2125.
- Hopgood, A. A.; Hirst, A. J., (2004) "Keeping a distance-education course current through e-learning and contextual assessment," *IEEE Transactions on Education*, (50: 1), pp. 85-96.
- Hwang, Y., (2005) "Investigating enterprise systems adoption: Uncertainty avoidance, intrinsic motivation, and the technology acceptance model," *European Journal of Information Systems*, (14:2), pp. 150-161.
- Janicki, T., & Steinberg, G., (2006) "Evaluation of a computer-supported learning system," *Decision Sciences Journal of Innovative Education*, (1: 2), pp. 203-223.
- Janz B.D., & Prasarnphanich, P., (2003) "Understanding the antecedents of effective knowledge management: The importance of a knowledge-centered culture," *Decision Sciences*, (34: 2), pp. 351-384.
- Kelman, H. C. (1958) "Compliance, identification, and internalization: Three processes of attitude change," *Journal of Conflict Resolution*, (2), pp. 51-60.
- Kelman, H.C., (1961) "Processes of opinion change," *Public Opinion Quarterly*, (25), pp. 57-78.
- Ko, D., Kirsch, L. J., & King, W. R., (2005) "Antecedents of knowledge transfer from consultants to clients in enterprise system implementations," *MIS Quarterly*, (29:1), pp. 59-85.
- Laurillard, D., (2004) "New technologies and the curriculum," in Scott, P., (Ed.) *Higher Education Reformed*, Falmer Press, London, pp. 133-153.
- Lee, Y., Lee, J., & Lee, Z., (2001) "The effect of self identity and social identity on technology acceptance," *The Proceedings of 22th International Conference on Information Systems*, pp. 481-490.
- Lewis, W., Agarwal, R., & Sambamurthy, V., (2003) "Sources of influence on beliefs about information technology use: An empirical study of knowledge workers", *MIS Quarterly*, (27:4), pp. 657-678.
- Mael, F. A., & Tetrick, L. E., (1992) "Identifying organizational identification," *Educational and Psychological Measurement*, (52), pp. 813-824.
- Malhotra, Y., (2002) "Is knowledge management really an oxymoron? Unraveling the role of organizational controls in knowledge management," in D. White (ed.), *Knowledge Mapping and Management*, Hershey, PA: Idea Group Publishing, pp. 1-13.
- Malhotra, Y., & Galleta, D., (2003) "Role of commitment and motivation in knowledge management systems implementation: Theory, conceptualization, and measurement of antecedents of success," in *Proceedings of the Thirty Sixth Hawaii International Conference on Systems Sciences*, Sprague, R. H. (Ed.), Los Alamitos, CA: IEEE Computer Society Press.
- Malhotra, Y., & Galleta, D., (2005) "A multidimensional commitment model of volitional systems adoption and usage behavior," *Journal of MIS*, (22:1), pp. 117-151.
- Mattila, A., & Wirtz, J., (2000) "The role of preconsumption affect in post purchase evaluation of services," *Psychology & Marketing*, (17:7), pp. 587-605.
- Moore, G., & Benbasat, I., (1991) "Development of instrument to measure the perceptions of adopting an information technology innovation," *Information Systems Research*, 2 (3), pp. 192-222.
- O'Reilly, C., & Chatman, J., (1986) "Organizational commitment and psychological attachment: The effects of compliance, identification, and internalization on prosocial behavior," *Journal of Applied Psychology*, (71:3), pp. 492-499.
- Pearl, J. (2000), *Causality: Models, Reasoning, and Inference*, Cambridge University Press.
- Powell, A., Galvin, J., & Piccoli, G., (2007) "Antecedents to team member commitment from near and far: A comparison between collocated and virtual teams," *Information Technology & People*, (19: 4), pp. 299-322.
- Piccoli, G., Ahmad, R., & Ives, B., (2001) "Web-based virtual learning environments: A research framework and a preliminary assessment of effectiveness in basic IT skills training," *MIS Quarterly*, (25:4), pp. 401-426.
- Poole, D.M., (2000) "Student participation in a discussion-oriented online course: A case study," *Journal of Research on Computing Education*, (33), pp. 162-177.
- Rourke, L., & Anderson, T., (2002) "Exploring social interaction in computer conferencing," *Journal of Interactive Learning Research*, (13: 3), pp. 257-273.
- Rungtusanatham, M., Ellram, L., Siferd, S., & Salik, S., (2003) "Toward a typology of business education in the Internet age," *Decision Sciences Journal of Innovative Education*, (2: 2), pp. 101-120.
- Siau, K.; Sheng, H.; Nah, F.F.-H., (2003) "Use of a classroom response system to enhance classroom interactivity," *IEEE Transactions on Education*, (49: 3), pp. 398-403.
- Sparks, P., & Shepherd, R., (1992) "Self-identity and the theory of planned behavior: Assessing the role of identification with green consumerism," *Social Psychology Quarterly*, (55: 4), pp. 388-399.
- Sun, H., & Zhang, P., (2006) "The role of affect in IS research: A critical survey and a research model", in *HCI in MIS (I)*:

- Foundations*, Zhang, P. & Galletta, D. (eds.) *Series of Advances in Management Information Systems*, M.E. Sharpe Publisher, pp. 121-142
- Tajfel, H., (1982) *Social Identity and Intergroup Behavior*. Cambridge, England: Cambridge University Press.
- Tajfel, H. & Turner, J. C. (1986) "An integrative theory of intergroup conflict," in S. Worchel & W. Austin (Eds.), *Psychology of Intergroup Relations* (pp. 2-24), Chicago: Nelson-Hall.
- Tannen, D., (1991) "Teachers' classroom strategies should recognize that men and women use language differently," *The Chronicle of Higher Education*, June 19, pp. 1-3.
- Terry, D. J., Hogg, M. A., & White, K. M., (1999) "The theory of planned behavior: Self-identity, social identity, and group norms," *British Journal of Social Psychology*, (38), pp. 225-244.
- Turner, J., (1982) "Toward a cognitive resolution of the social group," in *Social Identity and Intergroup Relations*, Tajfel, H. (ed.), Cambridge University Press, Cambridge, England.
- Venkatesh, V. & Davis, F.D. (2000) "A Theoretical extension of the technology acceptance model: Four longitudinal field studies," *Management Science*, (46:2), pp. 186-204.
- Venkatesh, V., & Speier, C., (2000) "Creating an effective training environment for enhancing telework," *International Journal of Human-Computer Studies*, (52), pp. 991-1005.
- Wasko, M. M., & Faraj, S., (2005) "Why should I share? Examining social capital and knowledge contribution in electronic networks of practice," *MIS Quarterly* (29:1), pp. 35-57.
- Webster, J. & Ho, H., (1997) "Audience engagement in multimedia presentation," *Data Base for the Advances in Information Systems*, (28: 2), pp. 63-77.
- Wold, H. (1982) "Systems under indirect observation using PLS," in *A Second Generation of Multivariate Analysis*, Fornell, C. & Bookstein, L., (Ed.). Praeger, New York, pp. 325-347.
- Yi, M. Y., & Davis, F. D., (2003) "Developing and validating an observational learning model of computer software training and skill acquisition," *Information Systems Research*, (14:2), pp. 146-169.
- Yi, M. Y., & Hwang, Y., (2003) "Predicting the use of web-based information systems: Self-efficacy, enjoyment, learning goal orientation, and the technology acceptance model," *International Journal of Human-Computer Studies*, (59:4), pp. 431-449
- Zack, M. H. (2001) "If managing knowledge is the solution, then what's the problem?" In Malhotra, Y. (Ed.), *Knowledge Management and Business Model Innovation*, Hershey, PA: Idea Group Publishing.

#### AUTHOR BIOGRAPHY

**Yujong Hwang** is an Assistant Professor of MIS/e-Business at the School of Accountancy and MIS, DePaul University in Chicago. He was also appointed as a Visiting Professor at the Kellogg School of Management and the McCormick School of Engineering and Applied Science in Northwestern University. He earned his Ph.D. in MIS/accounting at the University of South Carolina. His current research focuses on e-commerce, knowledge management, and human-computer interaction. His research has been published in *Journal of Management Information Systems*, *Communications of the ACM*, *IEEE Transactions on Professional Communication*, *European Journal of Information Systems*, *Decision Support Systems*, *International Journal of Electronic Commerce*, *International Journal of Human-Computer Studies*, among others. He is an Associate Editor of *Journal of Electronic Commerce Research* and a Guest Editor of *Journal of Organizational and End User Computing*. He is the recipient of a Quality of Instruction Council Grant Award from DePaul University.



Appendix 1.

Items, Item-to-total Correlations, and Reliability of Pilot Test (n=155)

Note. SOI: Social Identity, SEI: Self Identity, IDE: Identification, ENJ: Perceived Enjoyment of Knowledge Sharing by TML, ATT: Attitude of Knowledge Sharing by TML.

Construct	Items	Item to total	Reliability
SOI1	In general, I am very interested in what the group members think about sharing my knowledge by email.	.51	.79
SOI2	<i>I feel the belongingness to the group when I share my knowledge by email.</i>	.71	
SOI3	<i>I feel I will fit into the group when I share my knowledge by email.</i>	.69	
SEI1	To share my knowledge by email is an important part of who I am as a group member.	.72	.85
SEI2	<i>As a group member, I am a type of person oriented to share my knowledge by email.</i>	.68	
SEI3	<i>I think of myself as a group member who is very concerned with sharing my knowledge by email.</i>	.75	
IDE1	<i>I am proud about sharing my knowledge by email in the group.</i>	.57	.77
IDE2	<i>I talk up my knowledge sharing by email to my group members as having great utility for me.</i>	.65	
IDE3	<i>I feel a sense of "ownership" for the knowledge sharing by email in the group.</i>	.61	
ENJ1	<i>I would find sharing my knowledge by email in the group to be enjoyable.</i>	.81	.89
ENJ2	<i>Sharing my knowledge by email in the group would be pleasant.</i>	.81	
ENJ3	<i>I would have fun sharing my knowledge by email in the group.</i>	.71	
ATT1	<i>My knowledge sharing with group members by email is a good idea.</i>	.67	.82
ATT2	<i>My knowledge sharing with group members by email is an enjoyable experience.</i>	.55	
ATT3	<i>My knowledge sharing with group members by email is valuable to me.</i>	.62	
ATT4	<i>My knowledge sharing with group members by email is a wise decision.</i>	.72	



### **STATEMENT OF PEER REVIEW INTEGRITY**

All papers published in the Journal of Information Systems Education have undergone rigorous peer review. This includes an initial editor screening and double-blind refereeing by three or more expert referees.

Copyright ©2008 by the Information Systems & Computing Academic Professionals, Inc. (ISCAP). Permission to make digital or hard copies of all or part of this journal for personal or classroom use is granted without fee provided that copies are not made or distributed for profit or commercial use. All copies must bear this notice and full citation. Permission from the Editor is required to post to servers, redistribute to lists, or utilize in a for-profit or commercial use. Permission requests should be sent to the Editor-in-Chief, Journal of Information Systems Education, [editor@jise.org](mailto:editor@jise.org).

ISSN 1055-3096