

5-15-2012

SIMULATING EXOGENOUS SHOCKS IN COMPLEX SUPPLY NETWORKS USING MODULAR STOCHASTIC PETRI NETS

Gilbert Fridgen
University of Augsburg

Christian Stepanek
University of Augsburg

Thomas Wolf
University of Augsburg

Follow this and additional works at: <http://aisel.aisnet.org/ecis2012>

Recommended Citation

Fridgen, Gilbert; Stepanek, Christian; and Wolf, Thomas, "SIMULATING EXOGENOUS SHOCKS IN COMPLEX SUPPLY NETWORKS USING MODULAR STOCHASTIC PETRI NETS" (2012). *ECIS 2012 Proceedings*. 195.
<http://aisel.aisnet.org/ecis2012/195>

This material is brought to you by the European Conference on Information Systems (ECIS) at AIS Electronic Library (AISeL). It has been accepted for inclusion in ECIS 2012 Proceedings by an authorized administrator of AIS Electronic Library (AISeL). For more information, please contact elibrary@aisnet.org.

SIMULATING EXOGENOUS SHOCKS IN COMPLEX SUPPLY NETWORKS USING MODULAR STOCHASTIC PETRI NETS

Fridgen, Gilbert, FIM Research Center, University of Augsburg, Universitätsstraße 12, 86159 Augsburg, Germany, gilbert.fridgen@wiwi.uni-augsburg.de

Stepanek, Christian, FIM Research Center, University of Augsburg, Universitätsstraße 12, 86159 Augsburg, Germany, christian.stepanek@wiwi.uni-augsburg.de

Wolf, Thomas, FIM Research Center, University of Augsburg, Universitätsstraße 12, 86159 Augsburg, Germany, thomas.wolf@wiwi.uni-augsburg.de

Abstract

Almost all major companies are embedded in complex, global supply networks, consisting of multiple nested supply chains, and building up a high level of complexity. Exogenous shocks on these networks (e.g. natural disasters) can directly and indirectly impact companies and even cause their entire supply network to fail. However, today it is extremely difficult for a company to predict the actual impact of an exogenous shock on its supply network. Hence, companies are not able to identify adequate counteractive measures. Therefore safeguarding measures are oftentimes insufficient or even counterproductive. This paper deals with modelling, analyzing and quantifying impacts of exogenous shocks on supply networks using Petri Nets. It provides means to simulate the vulnerability of different network constellations regarding exogenous influences. In order to evaluate the proposed method, we simulate different intensities of an exogenous shock delaying the delivery for an exemplary supply network. We thereby illustrate which results could be yielded from a real-world application. For our exemplary network we find that the marginal effect of a disruption declines with an increasing intensity of shock. Moreover, the impact of shocks can be mitigated by appropriate counteractive measures like in this example by an increased safety margin of stock.

Keywords: Supply Chain, Supply Network, Petri Net, Exogenous Shock.

Acknowledgement:

Grateful acknowledgement is due to the DFG (German Research Foundation) for their support of the project „IT-Portfoliomanagement (ITPM)“ (BU 809/10-1) making this paper possible.

1 Introduction

In the first half of 2011 about 45% of the world hard disk drive (HDD) supply was produced in Thailand (Bangkok Post 2011). The widespread flooding of Thailand in October/November of 2011 directly affected almost 30% of this capacity. Hence, affected companies all over the world face shortages in HDD supply up to the middle of 2012 (Zhang 2011). Today, almost all major companies of the global economic system are embedded in complex supply networks (Christopher, Lee 2004). We consider supply networks as a composition of many nested supply chains. On the one hand, this bears a lot of advantages (e.g., more flexibility in supplier decisions). On the other hand, these structures may increase dynamic interdependencies and therefore a company's exposure to risk (Hallikas et al. 2004). Interdependencies are further amplified by permanent optimization measures, taken by companies due to financial pressure and competition, which are besides others caused by globalization (Harland, Brenchley & Walker 2003). For example, in *just in time delivery* stock keeping is reduced to a minimum to save costs. This decreases the available buffer and hence increases temporal dependencies (Waters-Fuller 1995).

Aggregated dependencies between different entities moreover increase the exposure to risk of the network as a whole (Hallikas et al. 2004); the breakdown of one entity can cause the entire network to fail (Rice, Caniato 2003). This phenomenon is known as systemic risk: The financial crisis of 2008/2009, when the collapse of few financial institutions spread over the whole financial system and the real economy, is only one example. Supply networks are becoming increasingly vulnerable regarding impacts of exogenous shocks, too (Wagner, Neshat 2010). This paper provides means to simulate the behavior and compare different constellations of supply networks, in order to lower their vulnerability against exogenous shocks and consequently systemic risk.

Exogenous shocks can represent different incidents like natural disasters, resource shortages, economic crises or rapidly rising prices. They are stochastic events, able to affect different entities of the supply network in negative or positive ways. An exogenous shock, which is directly impacting one entity, can indirectly influence other entities due to its propagation through the supply network. It negatively impacts at least one entity directly. Considering e.g. competing entities it is however possible that a direct negative impact on one entity can lead to an indirect positive influence on another. Especially natural disasters like earthquakes, hurricanes and flashfloods are threatening supply networks all over the world. Indeed, the flooding of Thailand and the big earthquake in Japan in March of 2011 showed how fragile global supply networks are regarding such disruptions. For instance, after the earthquake in Japan many manufacturers recognized that parts were missing, but due to the lack of information about suppliers on the upstream, they were not able to immediately identify the responsible company (Rassweiler 2011). Suppliers in the context of this paper are considered to be either resource suppliers or manufacturers on the different upstream stages of the supply network. Hence, even if a company is not directly impacted by an exogenous shock, it may be threatened existentially due to the network structure. In order to diversify the risk of disruptions as far as possible, many manufacturers keep contractual relationships to different suppliers (Babich, Burnetas & Ritchken 2007). It is however still possible, that despite a perceived diversification on the preceding stages of the supply network, the complexity and the complementing direct and indirect dependencies can result in a disruption of the entire supply network (Buldyrev et al. 2010).

To govern such complex supply networks, an efficient management through information systems (IS) is required (Buhl, Penzel 2010). In this regard intelligent systems and processes can help to gain relevant network information (Buhl, Jetter 2009). Benefits like batch size and lead-time reduction, but also information sharing processes between the entities of the supply network, reflect the substantial contribution of information technology (IT) in the context of supply chain management (Cachon, Fisher 2000). This contribution serves all entities of the supply network (Subramani 2004). Formal methods of computer science or business and information systems engineering like Petri Nets can facilitate automation of information processing. Moreover, models based on such methods could then be integrated for example into existing ERP-Systems.

This paper supports the information evaluation process, in order to draw conclusions about structure and condition of supply networks. For simplifying matters, we assume all necessary information to be available. We introduce a feasible approach to provide entities the possibility to simulate and quantify impacts of exogenous shocks on their supply network. Furthermore, our approach constitutes the network structure by visualizing the single entities and their linkages. It enables the simulation of different supply network compositions being impacted by distinctive exogenous shocks. These compositions can be quantitatively evaluated in order to reduce weaknesses and bottlenecks. The results should empower companies to take adequate actions in order to stabilize their supply networks (not exclusively) regarding exogenous shocks.

2 Literature review

Managers tend to handle the impacts of shocks on supply networks as one-time events rather than a result of an inadequate supply network structure (Levy 1995). Even if shocks are one-time events, they nevertheless can threaten the existence of a company. Solid supply networks are able to bridge the disruption of one of their entities, but in case of fragile supply networks, a failure at any stage can cause the entire network to fail (Rice, Caniato 2003). Therefore shocks can uncover structural weaknesses of supply networks. Yet, the research filed of exogenous shocks impacting supply networks remains relatively untouched. Nevertheless, shocks are uncertain events and thus may be included in the field of uncertainty and risk.

Uncertainty and risk in supply networks has been widely discussed in literature. For instance, Vidal and Goetschalckx (2000) handle uncertainties in logistic systems by developing mixed integer models (MIP) based on mathematical programming, which are also used by Tsiakis et al. (2001). Blackhurst et al. (2004) describe potential methodologies to model uncertainty in supply chains and suggest a network-based approach to retain important information. Prater (2005) provides a framework of different types of uncertainty impacting supply networks. Sharratt and Choong (2002) present a methodology to assess operational and accidental risks in process industry projects. Hallikas et al. (2002) illustrates a risk analysis of production networks. Harland et al. (2003) focus on the influence of complexity, globalization and outsourcing on risk and its changing location in the supply network. Again Hallikas et al. (2004) furthermore notice that the accumulation of dependencies between companies leads to an increasing exposure to risk. Kleindorfer and Saad (2005) provide a conceptual framework, reflecting activities of risk assessment and mitigation for disruption risk management in supply networks. In order to quantify how disruptions propagate in supply chains, Wu et al. (2007) were the first to develop a *Disruption Analysis Network* (DA_NET) approach based on Petri Nets, which enables the adherence of different attributes, like stock or cost, to place and transition nodes.

Besides the numerous extensions and modifications of Petri Nets, there has been an extensive discussion about their application areas. In this regard, many articles on Petri Nets modelling production and manufacturing processes have been published. For example, Dubois and Stecke (1983) use Petri Nets to analyze control problems of production systems or Silva and Valette (1990) constitute how Petri Nets are used to support the production area in general. In the last years Petri Nets have also been successfully applied to model and analyze supply chains. For example, Dong and Chen (2001) analyze manufacturing supply chains based on object-oriented Petri Nets. Arns et al. (2002) propose a performance analysis for supply chain models, using stochastic Petri Nets and queuing networks. Desrochers et al. (2003) use complex-valued tokens to increase the descriptive abilities of ordinary Petri Nets to model supply chains. Fung et al. (2003) develop an XML-supported modular Petri Net-based approach to denote the workflow in supply chains. Blackhurst et al. (2004) reflect uncertainty in supply chains using a Petri Net-based model. Considering a scattered supply network, Dotoli and Fanti (2005) suggest to use a generalized stochastic Petri Net approach to model the management of distributed manufacturing systems.

Though different Petri Net variants and their application areas have been intensively discussed, the Petri Net based DA_NET approach of Wu et al. (2007) is the only one that focuses on the

quantification of disruptions in supply networks. As there has been little research on using formal methods of computer science or business and information systems engineering like Petri Nets to analyze and simulate the impact of exogenous shocks on supply networks, this research field remains relatively untouched to the best of our knowledge. Therefore we introduce an approach to visualize, analyze and simulate different compositions of supply networks in order to identify weaknesses and bottlenecks. Our model enhances the DA_NET approach, which enables the quantification of disruptions on straightforward supply *chains*. We need to modify this approach, as the modelling of supply *network* characteristics and the simulation of multiple order cycles require some additional features.

3 Modelling Language

Wu et al. (2007) contemplated a one directional flow of material respectively goods in a supply *chain*. We consider recurring bidirectional flows of materials and orders in a dynamic environment of miscellaneous entities. These flows can represent different supply chains. Therefore we use the expression supply *network*. To establish such a circular flow-situation, an operation of a supply network entity usually needs a defined input to create the according output. To model this situation with Petri Net elements, the operation represented by a transition needs to subtract/add a specific number of units from its input/to its output place. The DA_NET approach of Wu et al. calculates values for the output places of a specific fired transition only. Therefore the result of one calculation step, representing the firing of all activated transitions at a specific state of the network, is a matrix denoting the attributes of the output places. Information about the modification of the corresponding input places is not required, as in case of a one directional flow of goods each place is just considered once. Starting with the first place, the firing of transition one moves the focus represented by the token to the second place, the firing of transition two, to the third place and so on. Therefore in DA_NET it is not necessary to store information about the attributes of the input places, after the adjacent transition was fired. Within our approach, this information becomes compulsory when simulating multiple order cycles, as each succeeding cycle needs the information about how the input place was modified in the preceded cycle. Besides, each place has to be considered in order to get a general idea of the network condition.

To face complexity of large Petri Nets and enable an intuitive modeling of supply networks, we furthermore consider them as a composition of different *modules* (e.g. manufacturers, resource suppliers) representing the distinctive entities of the real-world network. Therefore we propose a modularization of the Petri Net in analogy to Dotoli and Fanti (2005), to facilitate the analysis of the overall network and theoretically also enable the examination of each single module. Furthermore the identified modules can be composed to distinctive supply networks.

3.1 Underlying Petri Net specification

Petri Nets are a formal modeling language, providing the possibility to simulate different states of a system by converting the network into a mathematical equation (van der Aalst, W. M. P., van Hee & Reijers 2000). The usefulness of Petri Nets to describe concurrent systems has shown a demand for more powerful net types (Jensen 1987). Hence, Petri Nets have been enhanced continuously. As the basic elements of classical Petri Nets (Petri 1962), are not sufficient to model exogenous shocks on supply networks, we apply some existing extensions thereby fulfilling the following requirements:

1. Since order and material flows of a supply network include different kinds of commodities with different characteristics, our Petri Net specification needs to contemplate this in adequate ways, e.g. by using different kinds of tokens or different attributes.
2. To model a realistic supply network the Petri Net specification must be able to reflect different input ratios of material for different production operations. Hence we require an extension including some kind of weighting of tokens.

3. As the volume of orders in the supply network depends on the consumers demand, the chosen Petri Net specification needs to be able to handle stochastic elements.
4. The natural limitation of resources as well as limited capabilities at manufacturer sites call for specific capacity restrictions, when modeling supply networks. Hence our Petri Net specification must feature places reflecting capacities.
5. Another important topic for modeling supply networks is the delivery time. Hence the Petri Net specification should also include some sort of timing.
6. The complexity and intransparency of large supply networks complicate the modeling and therefore the comprehensibility of an according Petri Net. Hence our specification should involve some kind of modularization, as this enhances the intuitive adaptability and practicability by increasing transparency and reducing the complexity of the model.

As similar requirements have been aroused for different application areas, appropriate Petri Net enhancements have already been developed (Drees et al. 1987). Regarding requirement (1), a development of the last decades was the transformation to so called *High-Level Petri Nets*. Instead of having one kind of token, *High-Level Petri Nets* feature several types of tokens, each able to carry complex information (Jensen 1991). Genrich and Lautenbach (1979) introduced *predicate/transition-nets* (Pr/T-nets). In order to handle technical problems by applying the method of place-invariants to the Pr/T-nets, Jensen (1981) developed an approach introducing different colors for different kinds of tokens (Jensen 1987). This extension of the original Pr/T-net is called *Coloured Petri Net*. Van der Aalst (1993) presented the *Interval Timed Coloured Petri Nets* (ITCPN), which are *Coloured Petri Nets* extended with time. In terms of practicability, Kristensen et al. (1998) presented their practitioner's guide to *Coloured Petri Nets*. Lakos (1995) enhanced *Coloured Petri Nets* in order to include object-oriented concepts. This approach is called *Object Petri Nets*. Another method, attaching attributes to place and transition nodes instead of moving colored tokens through the network, is the DA_NET approach of Wu et al. (2007). Regarding requirement (2) and (4), weights were added to the initial arcs, capacity constraints were added to the initial places and even new "inhibitor" arcs were created, to model systems with priorities (Murata 1989). Regarding requirement (3), for instance Molloy (1982) used stochastic Petri Nets for the purpose of performance analysis. Marsan et al. (1984) presented the *General Stochastic Petri Net* (GSPN) approach in order to evaluate system performance. Furthermore Marsan (1990) gave an introduction to *Stochastic Petri Nets* in general explaining why stochastic in most cases is considered together with timing and discussing strengths and weaknesses of the SPN approach. Regarding requirement (5), adding time features to the original Petri Net modeling language has been a major research area (Berthomieu, Diaz 1991). In this regard for example Ramchandani (1974) developed a *timed Petri Net* approach by associating a lead-time with each transition. Merlin (1974, 1976) presented his *time Petri Net*, associating two values of time with each transition: A lower bound a and an upper bound b . For $a = b$ Merlins *time Petri Nets* can easily be converted into Ramchandani's *timed Petri Nets* whereas the converse is not possible (Berthomieu, Diaz 1991). Regarding requirement (6), Dotoli and Fanti (2005) considered a modular Petri Net approach to be an appropriate methodology to model supply networks. Based on the concepts of the modular Petri Net markup language (PNML), Kindler and Petrucci (2009) formalized a minimal version of modular high-level Petri Nets.

Our paper uses weighted arcs to reflect the variety in material quantities and order volumes. It uses places with capacity constraints in order to depict limited capabilities and resources. Furthermore, transitions associated with firing conditions are used to govern the firing process. Theoretically, the requirement of representing distinctive characteristics of order and material flows can be fulfilled using miscellaneous specifications. However, we stick to the approach of Wu et al. (2007) attaching attributes to place and transition nodes, which bears the advantage of avoiding the exhausting exploration of token movements. Regarding time features, this paper sticks to the flexible approach of *time Petri Nets*. It considers stochastic elements by assuming a random distribution function for the firing of transitions with $a \neq b$ and $b \neq 0$. Furthermore it considers consumer demand to be

stochastic. The major disadvantage and hence the reason why Petri Nets are rare in practical applications, is the rising complexity when trying to model large supply networks (Murata 1989). To face this inconvenience we stick to the modular Petri Net approach of Dotoli and Fanti (2005). Using a limited number of standardized modules neither constricts the applicability nor the performance of Petri Nets, however it increases their transparency (Kindler, Petrucci 2009). Based on the mathematical equations of Petri Nets, it is possible to break them down to specific subnets and analyze each of them separately. Another advantage is the possibility of an intuitive graphical depiction. Furthermore the scalability and flexibility of Petri Nets offers a great application area.

3.2 Mathematical specification

The following mathematical definitions enable the quantitative modeling of the supply network and are basic principles for the simulation results at the end of this paper. They are however not compulsory for the comprehension of the paper's results. Each Petri Net is a composition of places, transitions and arcs. There are n transitions t_j with $j = 1 \dots n$ and m places p_i with $i = 1 \dots m$, each having specific properties. Besides there are arcs connecting places and transitions. We consider every transition t_j and every place p_i to have defined attributes d_{lj} with $l = 1 \dots L$ and c_{ki} with $k = 1 \dots K$. Hence each transition t_j has an attribute set $D_j = [d_{1j}, d_{2j}, \dots, d_{Lj}]$. Transitions respectively are activities, which are changing the attributes of their adjacent places. Each place p_i has an attribute set $C_i = [c_{1i}, c_{2i}, \dots, c_{Ki}]$ leading to a $K \times m$ - matrix C where each column represents one place's attribute set and each row is depicting the value of one specific attribute c_k for every place p_i . Therefore each row can be considered as an attribute set $C_k = [c_{k1}, c_{k2}, \dots, c_{km}]$.

$$C = \begin{bmatrix} c_{11} & \dots & c_{1m} \\ \vdots & \ddots & \vdots \\ c_{K1} & \dots & c_{Km} \end{bmatrix}$$

Next, we derive a $m \times n$ - matrix Z_k for each attribute c_k , depicting for each place p_i the modification of the underlying attribute caused by transition t_j . This modification is depicted as numeric value, which for instance can be derived from a function $f_j(c_{ki}, d_{lj})$ relating the attributes c_{ki} of the places with the attributes d_{lj} of the transition.

$$Z_k = \begin{bmatrix} z_{11} & \dots & z_{1n} \\ \vdots & \ddots & \vdots \\ z_{m1} & \dots & z_{mn} \end{bmatrix}$$

Each transition t_j has a decision logic E_j , which decides whether a transition is fired or not. It can be denoted as $E_j = \text{IF (constraint) THEN (consequence)}$.

Arcs can be divided into two subsets. The subset consisting of arcs pointing from places to transitions is defined as $P \times T \rightarrow \mathbb{N}$ and denoted by $Pre(p_i, t_j)$. The other one consisting of arcs pointing from transitions to places is defined as $T \times P \rightarrow \mathbb{N}$ and denoted as $Post(t_j, p_i)$. The binary variables $Pre(p_i, t_j)$ and $Post(t_j, p_i)$ equal 1, if there exists a specific arc between t_j and p_i . Otherwise they equal 0. The input places of a transition t_j are identified by monitoring the values of $Pre(p_i, t_j)$ in an $m \times n$ - input matrix I , while the output places are obtained in a $m \times n$ - output matrix O containing all $Post(t_j, p_i)$.

$$I = \begin{bmatrix} Pre(p_1, t_1) & \dots & Pre(p_1, t_n) \\ \vdots & \ddots & \vdots \\ Pre(p_m, t_1) & \dots & Pre(p_m, t_n) \end{bmatrix} \quad O = \begin{bmatrix} Post(t_1, p_1) & \dots & Post(t_n, p_1) \\ \vdots & \ddots & \vdots \\ Post(t_1, p_m) & \dots & Post(t_n, p_m) \end{bmatrix}$$

The relations between places and transitions however are already identified by the modifications of the matrices Z_k . Hence it is sufficient to compose just the input matrix I . Modified places, which are not monitored in I , can be considered as output places of the according transition.

In classical Petri Nets, the current number of tokens on each place node is called marking. As we consider a network of material and order flows, we contemplate places to be marked, if the quantity of their underlying (material/order) is greater than zero. These places contain exactly one token. The binary marking vector $M^h = [M^h(p_1), M^h(p_2), \dots, M^h(p_m)]$ with $h \in \mathbb{N}^0$ shows for each stage h of the marking process which place $p_{i=1, \dots, m}$ contains a token and which remains empty. It can be derived from the attribute matrix C or rather from the specific attribute set $C_k = [c_{k1}, c_{k2}, \dots, c_{km}]$ representing the attribute quantity. Consequently $M^h(p_i)$ is set to 1 if $c_{ki} > 0$ and to 0 if $c_{ki} = 0$. The firing vector $B^h = [b_1^h, b_2^h, \dots, b_n^h]$ of binary variables $b_j^h \in \{0; 1\}$ indicates whether a transition t_j is fired at stage h of a marking process. To calculate the firing vector B^h , we first need to sum up the values of each column of the input matrix I and denote them into a separate sum vector Y . Secondly a vector V^h for each stage h is derived according to the operation: $V^h = M^h \cdot I$.

Finally each element of Y is compared with the equivalent element of V^h . If the element of Y equals the element of V^h , the corresponding digit of B^h is set to 1 otherwise it is set to 0. Still there are two constraints determining the value of each b_j^h of B^h . First t_j has to be enabled, which depends on the marking M^h in connection with the input matrix I and second it is the decision logic E_j , deciding for each t_j whether and how this transition is fired.

The functional algorithm $F(C_k, Z_k, B)$ is a matrix operation, which defines how the firing of activated transitions affects the initial attribute sets of the different places. For each attribute we calculate an update of the attribute set C_k , denoting for each place the values of the attribute after the changeover from stage h to stage $h + 1$, by using the following equation with $(C_k^h)^T$ and $(B^h)^T$ being the transposed vectors of C_k^h and B^h :

$$(C_k^{h+1})^T = F(C_k, Z_k, B) = (C_k^h)^T + Z_k^h \cdot (B^h)^T$$

For each stage $h + 1$ we can derive the updated marking vector M^{h+1} from the updated attribute set C_k^{h+1} . Extending this coherence to a limited number of stages $H \in \mathbb{N}^0$ we derive the equation:

$$(C_k^H)^T = F(C_k, Z_k, B) = (C_k^0)^T + \sum_{h=0}^{H-1} Z_k^h \cdot (B^h)^T$$

3.3 Modularization

In this paper, entities of the network are connected by flows of orders and material of standardized goods. To account for requirement 6, each entity is illustrated as one module depicted by a rectangle. We extend the modules identified by Dotoli and Fanti (2005) as we consider them to be connected through order and material flows via interfaces located on their borderlines. Incoming and outgoing orders are depicted as interfaces on the top respectively the bottom while interfaces on the left and right hand side represent material inflow respectively material outflow. Since each order has a related delivery and the other way around, each order input interface has an according material output interface and each order output interface has an according material input interface. Figure 1 illustrates the structure of such a module and its interfaces.

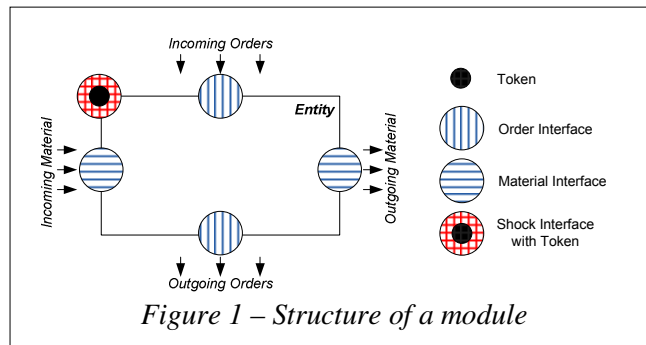

The interfaces are determined by their positioning on the borderlines or corners of the modules. Different interfaces on the same borderline can represent orders or material concerning different kinds of goods or different suppliers/customers. The red input interfaces in the left upper corner of the modules enable the impact of exogenous shocks. The output interfaces of a module are considered to be equal to the input interfaces of the aligned module. Modules can be aligned, by connecting an output interface of one module with the corresponding input interface of another. This modularization is expandable to an arbitrary number of interfaces. This requires an adaption of the Petri Net structures inside the module, though.

Each module represents its own stand-alone Petri Net. Its conversion into a mathematical equation is based on the same mechanisms as described above. Each input interface of module x has a corresponding output interface of an aligned module y , having the same attributes. In an integrated modular Petri Net those places have to be considered as one place p_i with $C_i = [c_{1i}, c_{2i}, \dots, c_{ki}]$.

4 Modelling Example

4.1 Procedure

According to Dotoli and Fanti (2005) we assume that a supply network can be modeled using four kinds of modules: *resource suppliers*, *manufacturers*, *retailers* and *logistic service providers*. In reality, other kinds of entities can also be involved in a supply network. We stick to these four entities for reasons of simplicity. Though, additional entities can easily be defined. Each module represents the complete Petri Net of its corresponding entity. Hence, the Petri Net structures inside the modules can be modeled flexibly, according to the desired complexity level. Figure 2 illustrates the four exemplary modules with their interfaces, although for reasons of simplicity in a very ingenious way. Due to the lack of space we refrain from describing the mechanism of the defined Petri Nets inside the modules in detail. Yet, we constitute that places are bearings with specific characteristics and transitions are activities. A bidirectional arc between a place and a transition indicates a capacity restriction. Transitions are enabled if all input places store tokens. The firing of an enabled transition additionally depends on the decision logic. In case a transition is enabled, the firing can change the attributes of the aligned places.

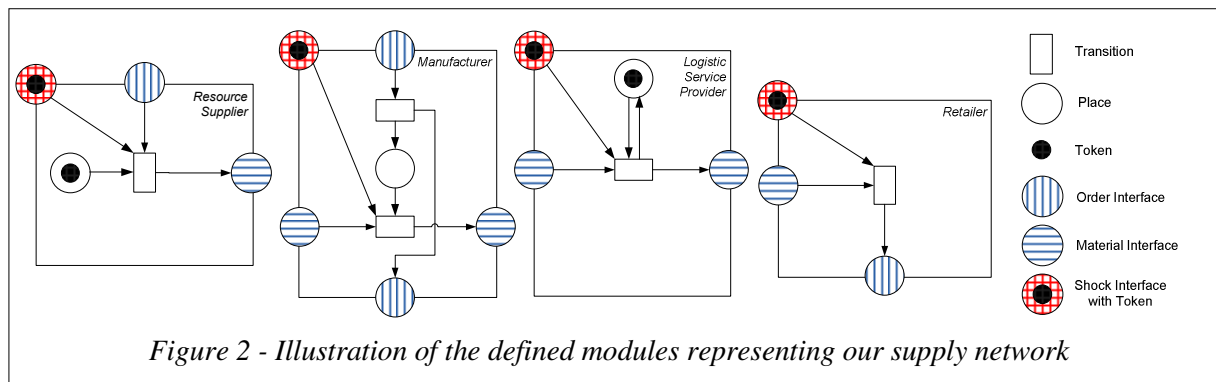

The *Resource supplier* has a finite amount of available resources. After receiving orders via its interface on the top, the resource supplier mines resources and processes them to its material outflow interface on the right. The *Manufacturer* receives an order via its interface on the top and material respectively goods via its material inflow interface on the left. The transitions respectively activities inside the module are the assembly process of the product and the ordering of spent material. The *Logistic Service Provider* is an intermediate, processing the goods received via the material inflow interface to the next entity of the network via its material outflow interface. For the processing transition we assumed a capacity restriction e.g. a limited number of ships/containers available for the transport of goods. This capacity restriction is depicted as a place inside the module. The *Retailer* can be seen as a consumer who orders goods via the order interface on the bottom of the module and

receives goods via the material inflow interface on the left. The only transition respectively activity of the retailer is the combined consumption and ordering process of the goods.

Depending on the modeling, shocks generally are able to affect any transition inside the module. To indicate such an exogenous shock in a supply network, we define a fifth correspondent module shown in Figure 3. In regard of the modularization each shock module includes a shock source. Furthermore it has an output interface on the right upper corner of the module, which is able to connect to the shock input interfaces of the other modules. The firing of the transition updates the attributes of the shock output place respectively the shock input place of the affected module, which consequently changes the module's behavior. Firing another token, which relocates the places attributes to the initial setting, can restore the original behavior.

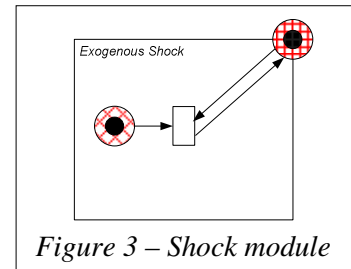

Figure 3 – Shock module

4.2 Simulation based analysis of an exemplarily supply network

Besides others, one possible application of our modular Petri Net approach is the analysis of supply network stability in context of stock availability. Figure 4 illustrates an example of a supply network composition impacted by an exogenous shock. In this example the supply network consists of a manufacturer with three supply stages B, C and D on the upstream, connected directly or by logistic service providers. Supplier C usually receives his ordered goods via ship (LSP1) from the resource supplier D. There is a more expensive possibility of an air freight delivery by another service provider (LSP2), which is activated only if LSP1 is disabled. In this initial setting an exogenous shock (e.g. a sea route blocking) occurs, impacting LSP1 by delaying its delivery time via ship.

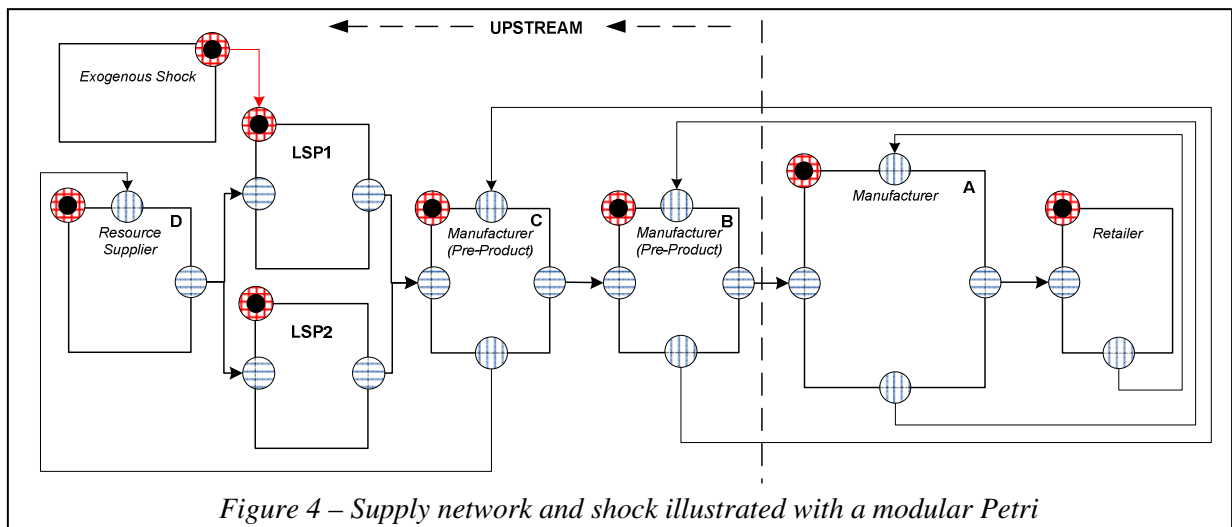

Figure 4 – Supply network and shock illustrated with a modular Petri

Considering the quantity of material and orders as the only attribute of interest for this example, we simulated this network based on the following assumptions:

- Logistic service providers, resource supplier and manufacturers have unlimited capacities.
- Each Manufacturer has a specific safety margin of stock.
- The stochastic customer demand represented by the outgoing order of the retailer is based on a normally distributed random variable with $\mu = 100$ and $\sigma = 50$ (outliers are cut at $\mu \pm 90$).
- The bearing of the retailer is depleted each period

Based on the retailer's stochastic order the manufacturers check if their stock is sufficient to cope with the incoming orders. They just order an appropriate amount of goods if the stock drops below the safety margin; however they keep on producing until their bearing is empty. Resource supplier and LSP on the other hand check if their capacities are sufficient to fulfill the order. If the capacity is not

sufficient, they are not able to deliver the ordered amount of goods. Each state of the Petri Net represents one period in time. Hence, the time until ordered goods arrive in the bearing of the ordering entity is normally two periods. The bearings of retailer and manufacturer are represented by the interfaces on the left border of the modules. Consequently, the safety margin of the manufacturers is based on the time spread between order and delivery and the average customer's demand. Taken this initial setting, we simulate 1000 periods of transient phase and 19000 periods of repeated shock phases within each simulation run. Simulation runs are done for different delays in delivery (shock intensities). Meanwhile, we monitor the stock of the retailer. We furthermore simulate different safety margins in order to gain information about the relation between stock and shock impact. We increase the initial margin of the manufacturer on stage C of the network in steps of 25% from 100% to 300%. The results, confirmed by statistical means, indicate that an increased safety margin reduces quantity and permanence of dropouts and hence the impact of a delay in delivery like shown in Figure 5. However, the absolute value of reduction seems to be declining with increasing level of safety margin. Moreover, the benefit of increasing the safety margin seems to decline with the safety margin's extend. Thus, in order to reduce the number of disruptions at the retailers end, it might be more effective to convince multiple companies on the upstream to increase their safety stock than exceedingly pushing up just one company's safety stock. A further indication of these results is, that while the overall number of disruptions rises with an increasing delay in delivery, the marginal number of disruptions declines.

The results of such a simulation process could for instance be used, to answer questions like *which quantity of a particular resource is needed as strategic reserve, in order to ensure supply availability to a given level of probability?* This small simulation focusing on logistical problems was just an exemplary application of the presented approach, though. More detailed simulations and analysis of this and other problems are subject to further research.

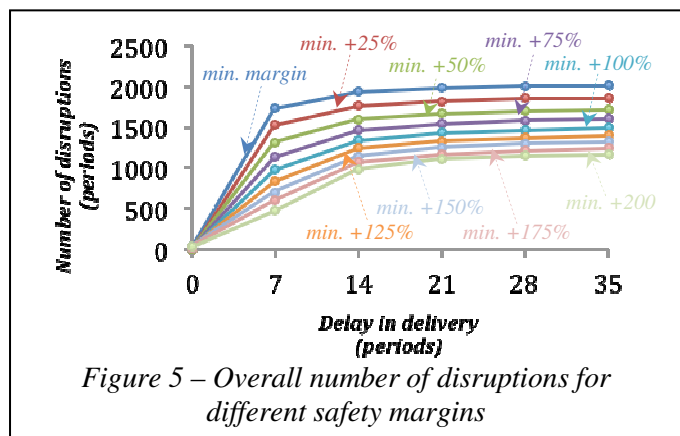

Figure 5 – Overall number of disruptions for different safety margins

5 Summary and conclusion

Although the impacts of exogenous shocks on global supply networks are hard to predict, the incidences of the last years showed the necessity for support from research. We presented a modular Petri Net approach to quantify and simulate such impacts in order to gain information about network behavior and stability regarding exogenous shocks. Though, this approach is not without limitation. The applicability is restrained by the availability of data and information about the network structures and condition. Therefore, further research should focus on the development of systems and approaches for the acquisition of relevant information. As supply networks are becoming increasingly complex and opaque, the application of high-performing Information Systems (IS) is necessary to handle, route and process the huge amount of critical information compulsory for the analyses of such networks. Therefore, if continuing research in this area is adopted, it should investigate appropriate supply chain comprehensive systems to enable and facilitate the analyses of complex supply networks. Hence, IS research could induce a stabilizing effect on otherwise instable and endangered parts of our economy.

References

Arns, M., Fischer, M., Kemper, P. & Tepper, C. 2002, "Supply Chain Modelling and Its Analytical Evaluation", *The Journal of the Operational Research Society*, vol. 53, no. 8, pp. 885-894.

- Babich, V., Burnetas, A.N. & Ritchken, P.H. 2007, "Competition and Diversification Effects in Supply Chains with Supplier Default Risk", *Manufacturing and Service Operations Management*, vol. 9, no. 2, pp. 123-146.
- Bangkok Post 2011, *Bangkok Post: PC shortage looming through H1 next year*. Available: <http://www.bangkokpost.com/business/economics/265890/pc-shortage-looming-through-h1-next-year> [2011, 11/14].
- Berthomieu, B. & Diaz, M. 1991, "Modeling and Verification of Time Dependent Systems Using Time Petri Nets", *IEEE Transactions on Software Engineering*, vol. 17, no. 3, pp. 259-273.
- Blackhurst, J., Wu, T. & O'Grady, P. 2004, "Network-based approach to modelling uncertainty in a supply chain", *International Journal of Production Research*, vol. 42, no. 8, pp. 1639-1658.
- Buhl, H.U. & Jetter, M. 2009, "BISE's Responsibility for our Planet", *Business & Information Systems Engineering*, vol. 1, no. 4, pp. 273-276.
- Buhl, H.U. & Penzel, H. 2010, "The Chance and Risk of Global Interdependent Networks", *Business & Information Systems Engineering*, vol. 2, no. 6, pp. 333-336.
- Buldirev, S.V., Parshani, R., Paul, G., Stanley, H.E. & Havlin, S. 2010, "Catastrophic cascade of failures in interdependent networks", *Nature*, vol. 468, pp. 1025-1028.
- Cachon, G.P. & Fisher, M. 2000, "Supply Chain Inventory Management and the Value of Shared Information", *Management Science*, vol. 46, no. 1, pp. 1032-1048.
- Christopher, M. & Lee, H. 2004, "Mitigating supply chain risk through improved confidence", *International Journal of Physical Distribution & Logistics Management*, vol. 34, no. 5, pp. 388-396.
- Desrochers, A.A., Deal, T.J. & Fanti, M.P. 2003, "Complex Token Petri Nets", *Proceedings of the IEEE International Conference of Systems, Man and Cybernetics*, vol. 2, pp. 1153-1160.
- Dong, M. & Chen, F.F. 2001, "Process modeling and analysis of manufacturing supply chain networks using object-oriented Petri nets", *Robotics and Computer Integrated Manufacturing*, vol. 17, no. 1-2, pp. 121-129.
- Dotoli, M. & Fanti, M.P. 2005, "A Generalized Stochastic Petri Net Model for Management of Distributed Manufacturing Systems", *44th IEEE Conference on Decision and Control*, pp. 2125-2130.
- Drees, S., Gomm, D., Plünnecke, H., Reisig, W. & Walter, R. 1987, "Bibliography of Petri nets", *Lecture Notes in Computer Science*, vol. 266, no. 24, pp. 309-451.
- Dubois, D. & Stecke, K.E. 1983, "Using Petri nets to represent production processes", *Proceedings of the 22nd IEEE Conference on Decision and Control, 1983*, pp. 1062-1067.
- Fung, R.Y.K., Au, Y.M., Jiang, Z.B. & Lau, H.C.W. 2003, "Supply chain workflow modelling using XML-formatted modular petri nets", *The International Journal of Advanced Manufacturing Technology*, vol. 22, no. 7-8, pp. 587-601.
- Genrich, H.J. & Lautenbach, K. 1979, "The Analysis of Distributed Systems by Means of Predicate/Transition-Nets", *Lecture Notes in Computer Science*, vol. 70, pp. 123-146.
- Hallikas, J., Karvonen, I., Pulkkinen, U., Virolainen, V. & Tuominen, M. 2004, "Risk management processes in supplier networks", *International Journal of Production Economics*, vol. 90, no. 1, pp. 47-58.
- Hallikas, J., Virolainen, V. & Tuominen, M. 2002, "Risk analysis and assessment in network environments: A dyadic case study", *International Journal of Production Economics*, vol. 78, no. 1, pp. 45-55.
- Harland, C., Brenchley, R. & Walker, H. 2003, "Risk in supply networks", *Journal of Purchasing & Supply Management*, vol. 9, no. 3, pp. 51-62.
- Jensen, K. 1991, "Coloured Petri Nets: A High Level Language for System Design and Analysis", *Lecture Notes in Computer Science*, vol. 483, pp. 342-416.
- Jensen, K. 1987, "Coloured Petri Nets", *Lecture Notes in Computer Science*, vol. 254, pp. 248-299.
- Jensen, K. 1981, "Coloured Petri Nets and the Invariant-Method", *Theoretical Computer Science*, vol. 14, no. 3, pp. 317-336.
- Kindler, E. & Petrucci, L. 2009, "Towards a Standard for Modular Petri Nets: A Formalisation", *Proceedings of the Application and Theory of Petri Nets, 30th Int. Conference*, pp. 43-62.

- Kleindorfer, P.R. & Saad, G.H. 2005, "Managing Disruption Risks in Supply Chains", *Production and Operations Management*, vol. 14, no. 1, pp. 53-68.
- Kristensen, L.M., Christensen, S. & Jensen, K. 1998, "The practitioner's guide to coloured Petri nets", *International Journal on Software Tools for Technology Transfer*, vol. 2, no. 2, pp. 98-132.
- Lakos, C. 1995, "From Coloured Petri Nets to Object Petri Nets", *Lecture Notes in Computer Science*, vol. 935, pp. 278-297.
- Levy, D. 1995, "International Sourcing and Supply Chain Stability", *Journal of International Business Studies*, vol. 26, no. 2, pp. 343-360.
- Marsan, M.A. 1990, "Stochastic Petri nets: An elementary introduction", *Lecture Notes in Computer Science*, vol. 424, pp. 1-29.
- Marsan, M.A., Conte, G. & Balbo, G. 1984, "A Class of Generalized Stochastic Petri Nets for the Performance Evaluation of", *ACM Transactions on Computer Systems*, vol. 2, no. 2, pp. 93-122.
- Merlin, P. 1974, "A study of the recoverability of computer system", *University of California*.
- Merlin, P. & Farber, D. 1976, "Recoverability of communication protocols", *IEEE Transactions on communications*, vol. COM-24, no. 9.
- Molloy, M.K. 1982, "Performance Analysis Using Stochastic Petri Nets", *IEEE Transactions on Computers*, vol. 31, no. 9, pp. 913-917.
- Murata, T. 1989, "Petri Nets: Properties, Analysis and Applications", *Proceedings of the IEEE*, vol. 77, no. 4, pp. 541-580.
- Petri, C.A. 1962, "Communication with Automata", *Proceedings of the IIM*, no. 3.
- Prater, E. 2005, "A framework for understanding the interaction of uncertainty and information systems on supply chains", *International Journal of Physical Distribution & Logistics Management*, vol. 35, no. 7, pp. 524-539.
- Ramchandani, C. 1974, "Analysis of asynchronous concurrent systems by timed Petri nets", *Massachusetts Institute of Technology*.
- Rassweiler, A. 2011, *Japanese Earthquake Poses Potential Supply Problems for iPad 2*. Available: <http://www.isuppli.com/teardowns/news/pages/japanese-earthquake-poses-potential-supply-problems-for-ipad-2.aspx> [2011, 11/12].
- Rice, J. & Caniato, F. 2003, "Building a secure and resilient supply network", *Supply Chain Management Review*, vol. 7, no. 5, pp. 22-30.
- Sharratt, P.N. & Choong, P.M. 2002, "A life-cycle framework to analyse business risk in process industry projects", *Journal of Cleaner Production*, vol. 10, no. 5, pp. 479-493.
- Silva, M. & Valette, R. 1990, "Petri nets and flexible manufacturing", *Lecture Notes in Computer Science*, vol. 424, pp. 374-417.
- Subramani, M. 2004, "How Do Suppliers Benefit from Information Technology Use in Supply Chain Relationships?", *MIS Quarterly*, vol. 28, no. 1, pp. 45-73.
- Tsiakis, P., Shah, N. & Pantelides, C.C. 2001, "Design of Multi-echelon Supply Chain Networks under Demand", *Industrial & Engineering Chemistry Research*, vol. 40, no. 16, pp. 3585-3604.
- van der Aalst, W. M. P. 1993, "Interval Timed Coloured Petri Nets and their Analysis", *Lecture Notes in Computer Science*, vol. 691, pp. 453-472.
- van der Aalst, W. M. P., van Hee, K.M. & Reijers, H.A. 2000, "Analysis of discrete-time stochastic Petri nets", *Statistica Neerlandica*, vol. 54, no. 2, pp. 237-255.
- Vidal, C.J. & Goetschalckx, M. 2000, "Modeling the effect of uncertainties on global logistics systems", *Journal of Business and Logistics*, vol. 21, no. 1, pp. 95-120.
- Wagner, S.N. & Neshat, N. 2010, "Assessing the vulnerability of supply chains using graph theory", *International Journal of Production Economics*, vol. 126, no. 1, pp. 121-129.
- Waters-Fuller, N. 1995, "Just-in-time purchasing and supply: a review of the literature", *International Journal of Operations & Production Management*, vol. 15, no. 9, pp. 220-236.
- Wu, T., Blackhurst, J. & O'Grady, P. 2007, "Methodology for supply chain disruption analysis", *International Journal of Production Research*, vol. 45, no. 7, pp. 1665-1682.
- Zhang, F. 2011, *Thailand Flood Exerts Broad Impact on Electronics Supply Chain*. Available: <http://www.isuppli.com/Memory-and-Storage/News/Pages/Thailand-Flood-Exerts-Broad-Impact-on-Electronics-Supply-Chain.aspx> [2011, 11/08].