

5-15-2014

# Social Support (or lack thereof) and Internal Drive: Factors that Connect Online Learners, Females, and First Generation College Students

Gaurav Bansal

*University of Wisconsin - Green Bay*, bansaig@uwgb.edu

Follow this and additional works at: <http://aisel.aisnet.org/mwais2014>

---

## Recommended Citation

Bansal, Gaurav, "Social Support (or lack thereof) and Internal Drive: Factors that Connect Online Learners, Females, and First Generation College Students" (2014). *MWAIS 2014 Proceedings*. 20.  
<http://aisel.aisnet.org/mwais2014/20>

This material is brought to you by the Midwest (MWAIS) at AIS Electronic Library (AISeL). It has been accepted for inclusion in MWAIS 2014 Proceedings by an authorized administrator of AIS Electronic Library (AISeL). For more information, please contact [elibrary@aisnet.org](mailto:elibrary@aisnet.org).

# Social Support (or lack thereof) and Internal Drive: Factors that Connect Online Learners, Females, and First Generation College Students

Gaurav Bansal

University of Wisconsin – Green Bay  
bansalg@uwgb.edu

## ABSTRACT

As more female and first generation college students (FGN) embrace higher-education – business in particular, and also as online learning gains more traction there is a need to explore the factors that drive the academic success of these learners. Online learners, female students and FGN all share a common bond, i.e. reduced social support. This study examines whether reduced social support – caused by technical (Internet/Online), cultural (females) and social (FGN) factors could have a parallel dampening, or other, influence on the impact of learning processes on learning outcomes for these students. The study relies on the 3P model of student learning to integrate diverse theories which substantiate reduced social support for these demographics, such as Media Richness for online learners, Stereotypes for females, and Social and Cultural Capital theories for FGN students. Data were collected from students enrolled in various business courses in a Midwestern University and analyzed using the Structural Equation Modeling approach.

## Keywords

Online learning, first generation college students, gender, academic performance

## INTRODUCTION

As online teaching becomes more mainstream, and similarly as more first generation college students (FGN) and more female students join the ranks of business college students, there is a need to explore the factors that drive the academic success of these learners. All three groups definitely share a common bond. Of course, all three are rising in ranks, but in addition to that they all are similarly experiencing to reduced social support. The online environment is constrained by reduced social support owing to technical limitations induced by the inherent low media richness built into the Internet; however female students and FGN students experience reduced social support owing to cultural and social circumstances – perhaps in the same respective order. This study examines whether reduced social support – caused by technical, cultural and social factors, could have a similar dampening influence on the impact of learning processes on learning outcomes. Similarly, the study examines whether the internal drive exhibited by these students has a similar escalating influence on learning outcomes. We rely on Media Richness, Stereotype and Social and Cultural Capital Theories to explain the reduced social support experienced by online learners, female undergraduates and FGN students respectively. We use the 3P model of student learning to integrate these theories, and argue that presage conditions (online learning medium, gender and FGN status) impact learning processes (engagement and perceived difficulty) which in turn impact learning outcomes (expected and actual grades).

Media Richness Theory ([Daft and Lengel 1986](#)) suggests that “[t]he absence of nonverbal vocal and physical cues [in the online learning environment] denies users important information about partners’ characteristics, emotions, and attitudes, resulting in less sociable, relational, understandable and/or effective communication” ([Walther et al. 2005 p. 37](#)). This is a serious limitation of online learning, and for many students it leads to poor quality of education ([Chau 2010](#)). However, it is quite unambiguous that online education does provide a convenience of where to study and when to study, along with offering excellent opportunities for placing students at the center of learning ([Stansfield et al. 2004](#)). These facts lead us to argue that online teaching is analogous to a double edged sword which facilitates or impedes one’s learning depending upon which side one ends up facing.

Stereotypes present a real threat. Men face genuine cultural barriers when considering careers outside what is deemed as “men’s work” just as women feel challenges in establishing themselves in what are known as traditional “men’s” jobs. Stereotypes are defined as the mental representations of the characteristics of a particular social or cultural group that are shared among the members of a society ([Stangor and Schaller 1996](#)). Such stereotype threats impede one’s performance. It is known that one performs more poorly under the influence of a stereotype threat than he/she would in the absence of any such threat ([Steele 2010](#)).

Similarly, FGN students enjoy limited social and cultural capital. They have restricted access to financial, informational, and family relationships and to the social networks enjoyed by traditional students. The lack of a strong social support network obviously makes things challenging for these students ([Pascarella et al. 2004](#)). However, it is argued that the lack of cultural capital makes these students more likely to benefit more from the academic experiences as they accumulate their cultural capital ([Pascarella et al. 2004](#)).

The rest of the paper is organized as follows: the next section presents a research model that examines the moderating effects of student characteristics on the relationship between learning processes (engagement and perceived difficulty) and expected and actual grades. The methodology, results, hypothesis testing, and discussion are then presented.

## RESEARCH MODEL

### Overarching Theory

The overarching theory is the 3P (Presage, Process, and Product) model of student learning ([Biggs and Moore 1993](#); [Cybinski and Selvanathan 2005](#); [Nemanich et al. 2009](#)). The model encapsulates the major factors affecting learning outcomes and suggests that learning (product: expected and actual grades) is a function of learning processes (engagement / perceived difficulty) which are shaped by presage conditions (online medium, gender, FGN status). The model is shown in Figure1.

Presage	Process	Product
Student variables, IQ, abilities, prior knowledge, subject area, teaching methods, personality, culture, home background, time constraints, course structure	Student motivation and behavior, student learning strategies	Exam results, self-concept, satisfaction, grade point average

**Figure1. The 3P Model of Student Learning**

Source: ([Cybinski and Selvanathan 2005](#))

### Learning Processes (Engagement & Perceived Difficulty) and Comparative Bias

Engagement is known to be associated with academic performance such as high grades ([Nemanich et al. 2009](#)). Engagement heightens the feeling of perceived control that would be associated with positive grade expectations as well. Students who are engaged tend to be motivated and also feel that they are in control ([Menona et al. 2009](#)). Conversely, perceived difficulty in a course would lower the feeling of control, and hence would lower the actual performance in the course. Comparative bias theory suggests that perceived control heightens one’s likelihood of a positive outcome ([Menona et al. 2009](#)). Conversely, when individuals perceive lower control over the outcome (e.g., lottery, low skill, and difficulty level) they make pessimistic comparisons. Thus,

*Hypothesis 1:* Engagement is positively associated with (a) expected grade; and also with (b) actual grade, such that (c) the relationship between engagement and expected grade is significantly stronger than the one between engagement and actual grade.

*Hypothesis 2:* Perceived difficulty level is negatively associated with (a) expected grade; and also with (b) actual grade, such that (c) the relationship between perceived difficulty and expected grade is significantly weaker than the one between perceived difficulty and actual grade.

Expectations would then be associated positively with actual grade performance. Hence,

*Hypothesis 3:* Expected grade is positively associated with actual grade.

## Online Students

Online classes provide students with greater convenience and flexibility which in turn saves one's energy and time. These classes often have online communities and provide facilities for online interaction – but the lack of direct social support does present some obvious limitations to the online interaction (Zhan and Mei 2013). Research suggests that online instruction works well for students who use online communication channels effectively (Peltier et al. 2003), stay focused, and avoid procrastinating (Elvers et al. 2003). Hence,

*Hypothesis 4<sub>ONL</sub>*: Online medium positively moderates the relationship between engagement and actual grades.

*Hypothesis 5<sub>ONL</sub>*: Online medium negatively moderates the relationship between perceived difficulty and actual grades.

## Female Students

Women typically are stereotyped as homemakers and hence, when they encounter difficulties in their academic or professional career, such difficulties heighten the stereotype threat (Steele 2010). Moreover, there are several soft skills where women in general outsmart men. Girls mature faster than boys (Lim et al. 2013), and tend to have a lower incidence of behavioral problems – especially in U.S. (Wanless et al. 2013). It is known that girls spend more time on their homework. Thus it could be argued that, on one hand, females face stereotype threats which would heighten the impact of perceived difficulty of a course, and on the other hand, their compensatory soft skills would heighten the impact of their engagement as well.

*Hypothesis 4<sub>FEM</sub>*: Female gender positively moderates the relationship between engagement and actual grades.

*Hypothesis 5<sub>FEM</sub>*: Female gender negatively moderates the relationship between perceived difficulty and actual grades.

## FGN Students

It is documented in literature that FGN students have limited support systems to enable them to cope with the challenges and difficulties faced in colleges. However, it is also argued that “first-generation students perhaps benefit more from their academic experiences than other students because these experiences act in a compensatory manner and thus contribute comparatively greater incremental increases in first-generation students’ stock of cultural capital” (Pascarella et al. 2004 p. 280). Hence,

*Hypothesis 4<sub>FGN</sub>*: FGN student status positively moderates the relationship between engagement and actual grades.

*Hypothesis 5<sub>FGN</sub>*: FGN student status negatively moderates the relationship between perceived difficulty and actual grades.

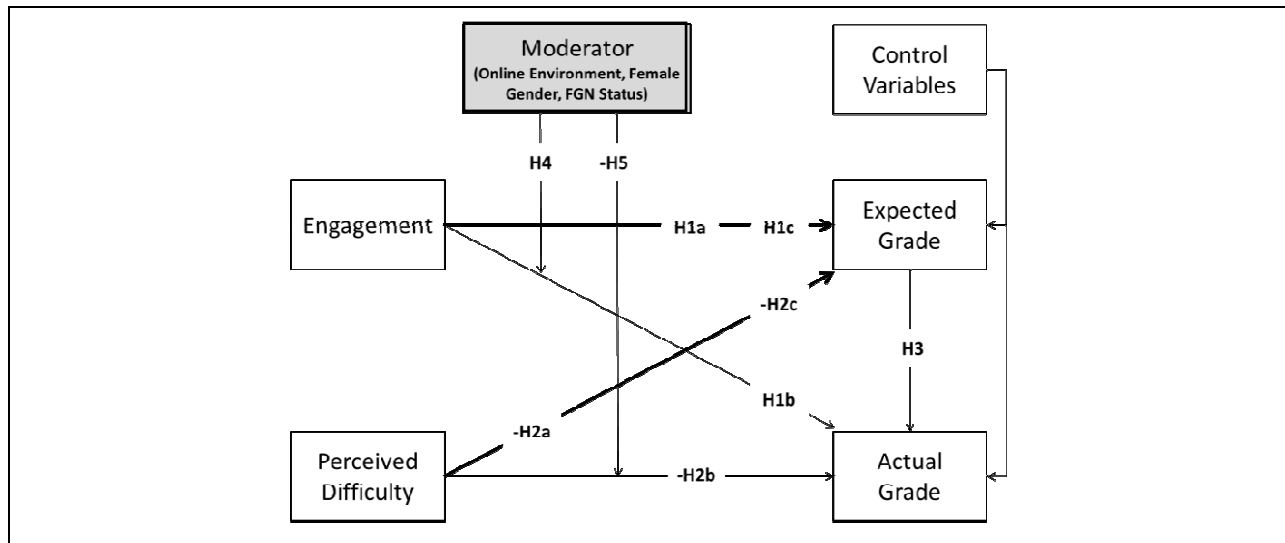

Figure2. The Research Model

## RESEARCH METHODOLOGY

Data were collected from business students studying in a Midwestern University using an online survey. A total of 342 responses were collected. The average age of the participants was 22.60 years (std dev = 6.35 years). Demographically there were 156 male and 183 female students; 140 FGN and 200 traditional students; 121 purely online, 178 face-to-face (F2F) students, and 43 students who were enrolled in hybrid classes (a combination of online and F2F instruction). Students were asked if they would allow their actual grade information to be integrated with their survey responses - 316 students responded positively. Some students didn't disclose their complete demographic information. We controlled for the students' personality and actual cumulative GPA – since these factors are known to impact one's learning outcomes. We also controlled for the course from which the students were recruited. We used semantic differential scale (0-10) to minimize common method variance ([Song and Zahedi 2005](#)).

Data were analyzed separately for the three models (online vs. F2F, females vs. males, FGN vs. traditional students). For each model we created two groups using the categorical variables (e.g., male=1; female=2) and analyzed the data using SEM based group analysis in MPlus ([Muthén and Muthén 1998-2012](#)). We first carried out CFA for all the three models. The factors had high factor loadings as well as high t-values. All indicators had significant R square values. Measurement model and estimation model fit indices provide confidence in the good fit of the models. Fit indices are reported in Table1.

H1a, H1b, H2a, H2b, and H3 were analyzed directly from MPlus outputs. H1c, H2c, H4, and H5 were computed by comparing the path coefficients and standard errors from their respective models using t-tests.

Fit indices	Measurement Models			Estimation Models			Threshold ( <a href="#">Song and Zahedi 2005</a> )
	F2F vs. Online	FGN Vs. Traditional	Females vs. Males	F2F vs. Online	FGN Vs. Traditional	Females vs. Males	
Normed Chi Sq	1.31	1.18	1.38	1.79	1.74	1.81	<3
CFI	0.97	0.99	0.97	0.90	0.92	0.91	>0.90
TLI	0.96	0.98	0.96	0.88	0.90	0.88	>0.90
RMSEA	0.05	0.03	0.05	0.08	0.07	0.07	<0.06
SRMR	0.05	0.05	0.05	0.08	0.08	0.08	<0.10

Table1. Fit Indices

## RESULTS

The results are shown in Figures 3, 4, and 5 and are consistent almost all of the hypotheses. We can see that engagement was always associated with expected grade (H3). Results support the Optimism bias (H1c) and Pessimism bias theories (H2c) in all the three x 2 scenarios. H1a and H2a had strong support in all six scenarios. Engagement (H1b) and Perceived difficulty (H2b) had a positive and negative impact on actual grades respectively for online and FGN students. Engagement did not lead to actual grade for females, but perceived difficulty did lower actual grades for females only. Thus, results show that the reduced social status in the form of online learners, female students and FGN status students was indeed responsible for aggravating the impact of perceived difficulty on actual grades (H5). H4 was strongly supported for both online and FGN students. We observed that the relationship between engagement and expected grades is stronger for females than it is for males – thus providing partial support for H4FEM. This area needs to be further explored.

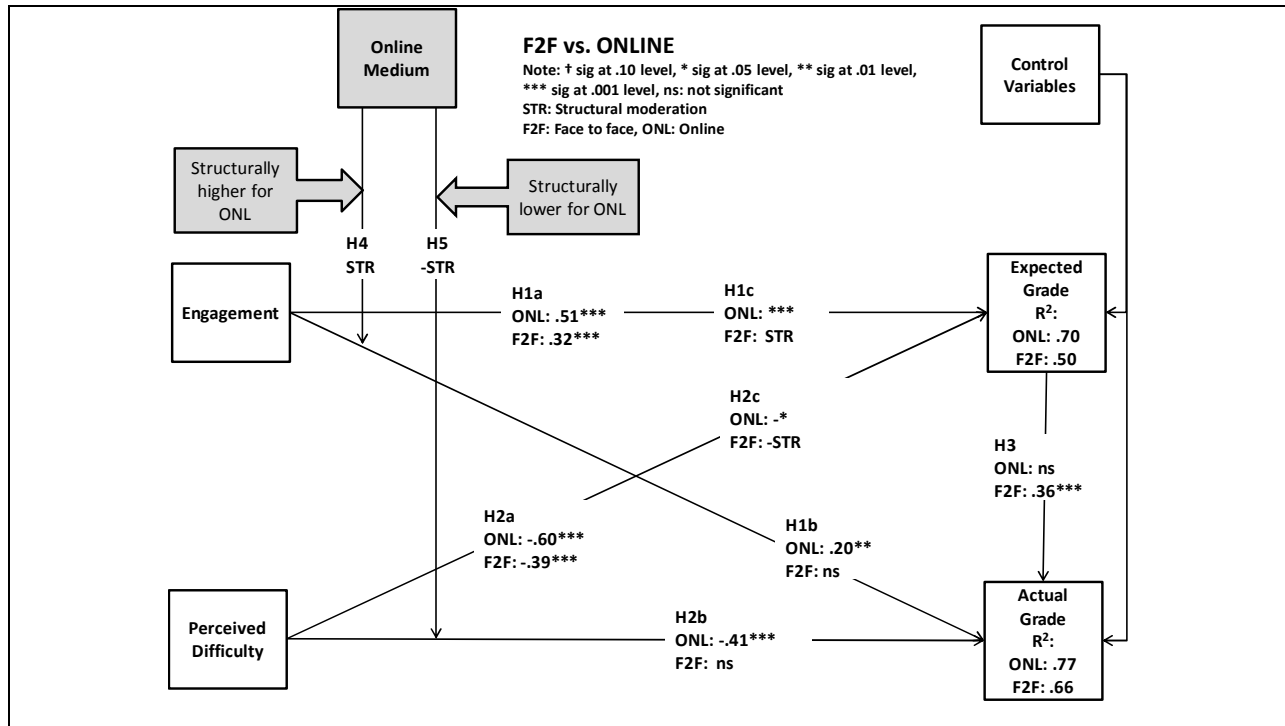

Figure3. Results (Online vs. F2F)

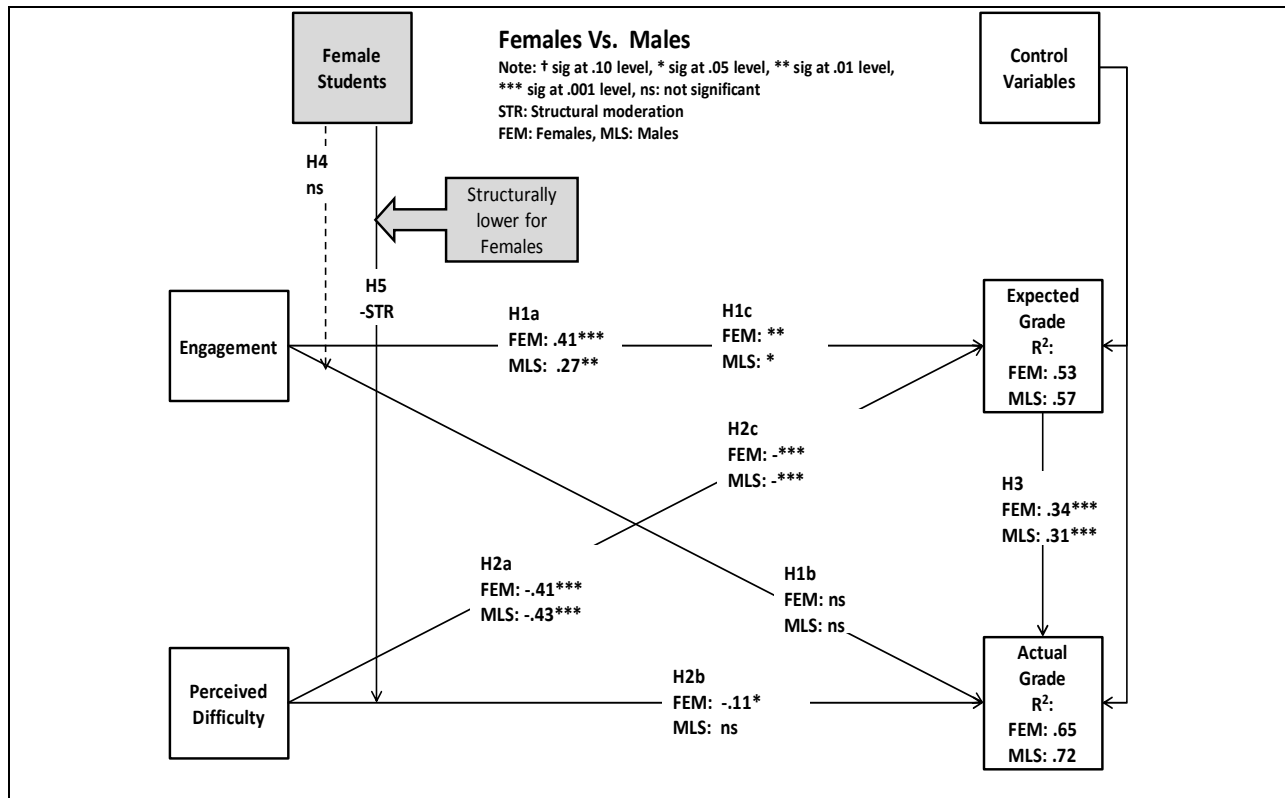

Figure4. Results (Females vs. Males)

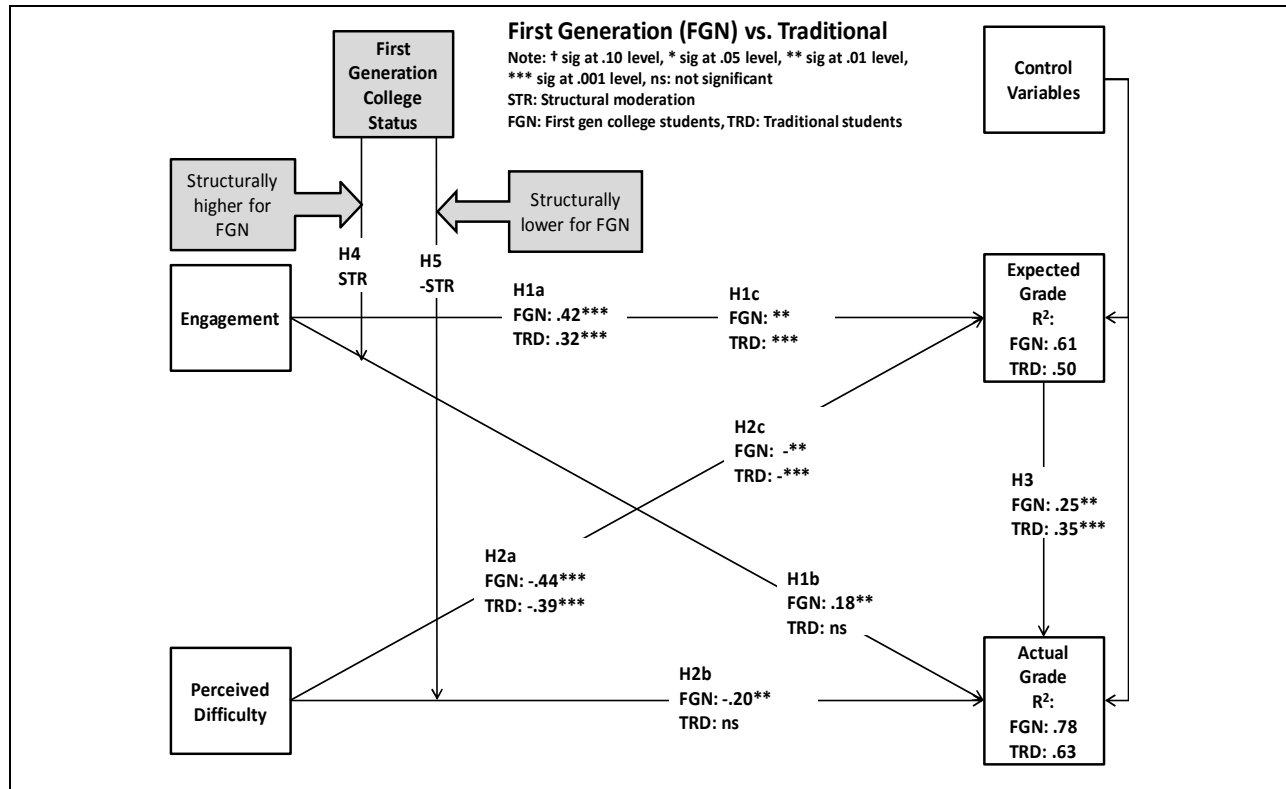

Figure5. Results (FGN Students vs. Traditional Students)

## DISCUSSION AND CONCLUSION

The work is among the first to shed light on the academic success factors of online, female and first generation college students in a comparative fashion. The study shows that social support, no matter how it is derived (or rather deprived) costs the same in terms of learning outcomes. In addition to the findings pertaining to the moderating impact of one's social status (online, gender and FGN) on engagement, perceived difficulty and actual grades, the research also shows the evidence of optimism and pessimism biases which reflect that for the same degree of engagement, students develop significantly higher grade expectations than the actual grades they receive. Similarly, for the same degree of perceived difficulty they develop significantly lower grade expectations than the actual grades they receive. Comparison of expected grades with actual grades extends comparative bias theory, which to the best of our knowledge, hitherto had been used to compare one's expectations in reference to others. These are significant findings which not only have theoretical but also social and pedagogical implications.

## ACKNOWLEDGEMENT

I would like to thank the Provost's Office at UW-Green Bay and the University of Wisconsin System - Office of Professional and Instructional Development (OPID-UW System) for their support in conducting this research.

## REFERENCES

- Biggs, J., and Moore, P. 1993. *The process of learning (3rd ed.)*, Prentice Hall: Australia.
- Chau, P. 2010. "Online higher education commodity," *Journal of Computing in Higher Education* (22:3), pp. 177-191.
- Cybinski, P., and Selvanathan, S. 2005. "Learning experience and learning effectiveness in undergraduate statistics: Modeling performance in traditional and flexible learning environments," *Decision sciences Journal of Innovative Education* (3), pp. 251-271.

- Daft, R. L., and Lengel, R. H. 1986. "Organizational information requirements, media richness and structural designs," *Management Science* (32), pp. 554-571.
- Elvers, G. C., Polzella, D. J., and Graetz, K. 2003. "Procrastination in online courses: Performance and attitudinal differences," *Teaching of Psychology* (30:2), pp. 159-162.
- Lim, S., Han, C. E., Uhlhaas, P. J., and Kaiser, M. 2013. "Preferential detachment during human brain development: Age- and sex-specific structural connectivity in diffusion tensor imaging (dti) data," *Cerebral Cortex*.
- Menona, G., Kyunga, E. J., and Agrawal, N. 2009. "Biases in social comparisons: Optimism or pessimism?," *Organizational Behavior and Human Decision Processes* (108), pp. 39-52.
- Muthén, L. K., and Muthén, B. O. 1998-2012. *Mplus User's Guide (Seventh Edition)*, Muthén & Muthén: Los Angeles, CA.
- Nemanich, L., Banks, M., and Vera, D. 2009. "Enhancing knowledge transfer in classroom vs. online settings: The interplay among instructor, student, content, and context," *Decision sciences Journal of Innovative Education* (7:1), pp. 123-148.
- Pascarella, E. T., Pierson, C. T., Wolniak, G. C., and Terenzini, P. T. 2004. "First-generation college students additional evidence on college experiences and outcomes," *The Journal of Higher Education* (75:3), pp. 249-284.
- Peltier, J. W., Drago, W., and Schibrowsky, J. A. 2003. "Virtual communities and the assessment of online marketing education," *Journal of Marketing Education* (25:3), pp. 260-276.
- Song, J., and Zahedi, F. M. 2005. "A theoretical approach to web design in e-commerce: A belief reinforcement model," *Management Science* (51:8), pp. 1219-1235.
- Stangor, C., and Schaller, M. 1996. "Stereotypes as individual and collective representations," in *Stereotypes and Stereotyping*, C. Neil Macrae, C. Stangor and M. Hewstone (eds.), Guilford: New York, pp. 3-37.
- Stansfield, M., McLellan, E., and Connolly, T. 2004. "Enhancing student performance in online learning and traditional face-to-face class delivery," *Journal of Information Technology Education* (3), pp. 173-188.
- Steele, C. M. 2010. *Whistling Vivaldi: How Stereotypes Affect Us and What We Can Do (Issues of Our Time)*, W. W. Norton & Company: New York, NY.
- Walther, J. B., Loh, T., and Granka, L. 2005. "Let me count the ways: The interchange of verbal and nonverbal cues in computer mediated and face-to-face affinity," *Journal of Language and Social Psychology* (24:1), pp. 36-65.
- Wanless, S. B., McClelland, M. M., Lan, X., Son, S.-H. C., Cameron, C. E., Morrison, F. J., Chen, F.-M., Chen, J.-L., Su Li, K. L., and Sung, M. 2013. "Gender differences in behavioral regulation in four societies: The U.S., Taiwan, South Korea, and China," *Early Childhood Research Quarterly*.
- Zhan, Z., and Mei, H. 2013. "Academic self-concept and social presence in face-to-face and online learning: Perceptions and effects on students' learning achievement and satisfaction across environments," *Computers & Education* (69), pp. 131-138.